

INSTALLATION & MAINTENANCE MANUAL
VFR8 Fixed Series

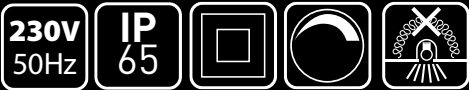

GENERAL INSTRUCTIONS

These instructions should be read carefully and retained after installation by the end user for future reference and maintenance.

These instructions should be used to aid installation of the following products:
VFR8WW / VFR8CW

SAFETY

- Installation of this luminaire should only be carried out by a qualified electrician or competent person to the current Building and IEE Wiring Regulations (BS7671)
- Please isolate mains prior to installation/maintenance
- Check the total load on the circuit (including when this luminaire is fitted) does not exceed the rating of the circuit cable, fuse or circuit breaker
- Please note the IP (Ingress of Protection) rating of this luminaire when deciding the location for installation
- This product is Class II double insulated
- This product is IP65 rated
- This product is dimmable
- Thermal Insulation should not be used to cover this product

INSTALLATION

Note – If this luminaire is being used in conjunction with a dimmer or an external PIR sensor, please confirm with the manufacturer of the equipment that the products are compatible with LED luminaires

- Provide power to the point of installation. Suitable IP rated junction boxes should be used where required
- Cut a suitable hole in the surface as per the cut-out details (see Fig 1) ensuring not to infringe with any joists, gas / water pipes or electrical cables

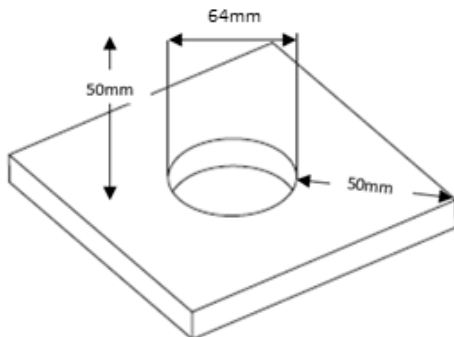

Fig 1

- Remove the terminal cover on the driver by inserting a screwdriver into the gap and gently prying (see Fig 2)

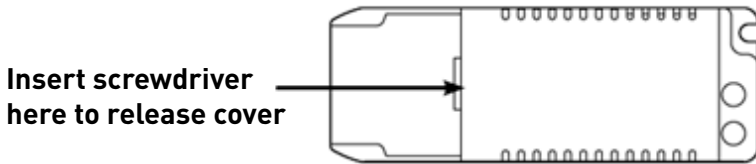

Fig 2

- Connect mains cable into the driver terminal block ensuring correct polarity is observed (see Fig 3)

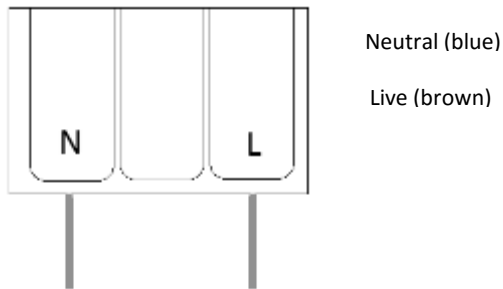

Fig 3

- Refit the driver terminal cover securing the mains cable under the cable clamp
- Place driver into the ceiling cavity
- Fit the downlight into the hole (see Fig 4)



Fold spring clips upwards and insert fitting into hole

Fig 4

BEZEL FITMENT/REPLACEMENT

Alternative colour bezels are available.

- To install the bezel, align the 2 lugs on either side of the bezel with the holes on the downlight
- Push the bezel lugs through the holes in the downlight and twist 30 degrees clockwise to lock into place
- To remove the bezel, twist 30 degrees anti-clockwise and pull down

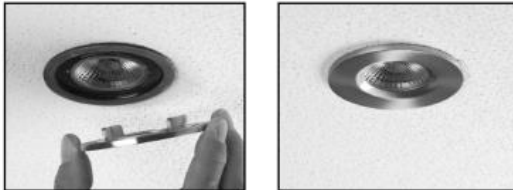

- Switch on and check for correct operation

GENERAL

The LEDs fitted in this product are non-replaceable. The unit should be recycled in the correct manner when it reaches the end of its life. Check local authorities for where facilities exist. Clean with a soft dry cloth only, do not use aggressive cleaning products or solvents which may damage the product.

Good ventilation should be provided at the back of this luminaire to allow heat dissipation.

WARRANTY

This product has a warranty of 4 years from date of purchase (conditions apply) see website for details. Failure to install this product in accordance with the current edition of the IEE Wiring Regulations, improper use, or removal of the batch codes will invalidate the warranty. If this product should fail within its warranty period it should be returned to the place of purchase for a free of charge replacement. ML Accessories does not accept responsibility for any installation costs associated with the replacement product. Your statutory rights are not affected. ML Accessories reserve the right to alter product specification without prior notice.



ML Accessories Limited
LU5 5TA
www.mlaccessories.co.uk

SBAUG17_V1