

TIMEGUARD®

Dedicated PIR Professional

LEDPROSLB & LEDPROSLWH



Installation & Operating Instructions

1. General Information

These instructions should be read carefully and retained for further reference and maintenance.

2. Safety

- Before installation or maintenance, ensure that the mains supply to this system is switched off and the circuit supply fused are removed or the circuit breaker turned off.
- It is recommended that a qualified electrician is consulted or used for the installations of this system and install in accordance with the current IEE wiring and Building Regulations.
- Check that the total load on the circuit including when this system is fitted does not exceed the rating of the circuit cable, fuse or circuit breaker.

3. Technical Specifications

- 230V AC 50Hz
- Maximum Switchable Load: LED lamp - 250W
Halogen lamp - 1000W
CFL - 400W
Fluorescent tube w/o PF correction - 500W
- Detection Range: Up to 12 meters
- Detection Angle: 180°
- Time ON Adjustment: 3 seconds - 18 minutes
- Dusk Level Adjustment: Day & night or night time only operation
- IP55 Rated suitable for restricted external applications
- CE Compliant

Dimensions

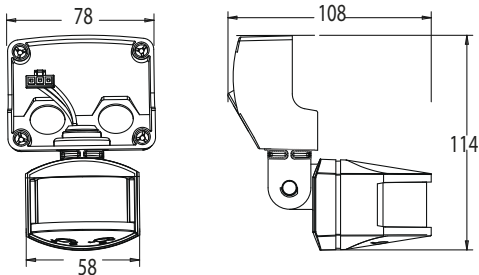

TOP VIEW

A



SIDE VIEW



C

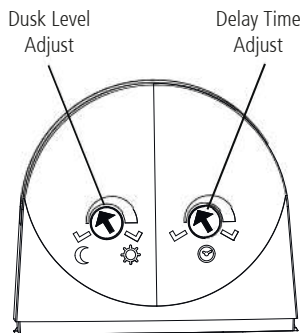

2

B

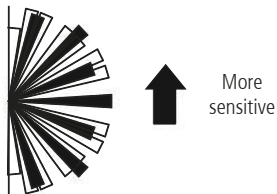
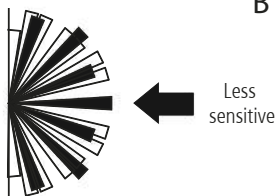

D

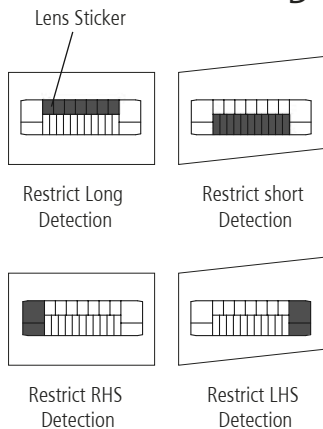

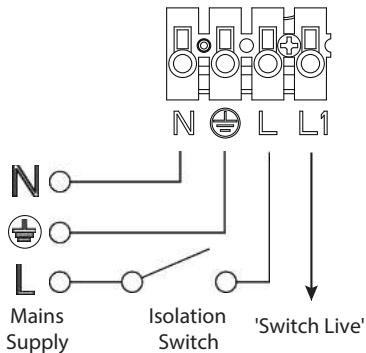

Note: Any floodlight connected to the L1 Switch Live terminal 'Live Output' will be controlled by the PIR

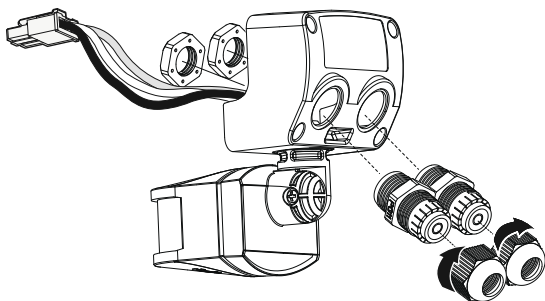

4. Selecting The Location

The motion detector has a number of detection zones, at various vertical and horizontal angles as shown (see diagram A).

A moving human body needs to cross/enter one of these zones to activate the sensor. The best all-round coverage is achieved with the unit mounted at the optimum height of 2.5m. If the unit is mounted any higher than this, the sensor will need to be angled down slightly to maintain coverage and forward coverage will be reduced.

Careful positioning of the sensor will be required to ensure optimum performance. See diagram A detailing detection range and direction.

The sensor is more sensitive to movement ACROSS its field of vision than to movement directly TOWARDS (see diagram B). Therefore position the unit so that the sensor looks ACROSS the likely approach path.

Avoid positioning the sensor where there are any sources of heat in the detection (extractor fans, tumble dryer exhausts etc.)

Reflective surfaces (ie pools of water or white-painted walls and overhanging branches) may cause false activation under extreme conditions.

During extreme weather conditions the motion sensor may exhibit unusual behaviour. This does not indicate a fault with the sensor. Once normal weather conditions return, the sensor will resume normal operation.

5. Installation

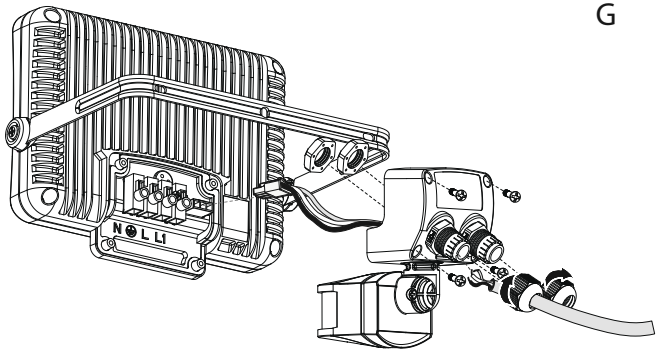

*** IMPORTANT ***

Switch off the electricity at the fuse box by removing the relevant fuse or switching off the circuit breaker before proceeding with the installation.

- Remove the jumper plug from the floodlight.

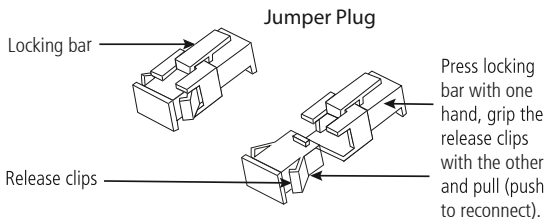

- Pass the mains supply and load cables the holes provided on the PIR ensuring that a cable gland, grommet or sealing compound is used to maintain the IP rating.

5

CONNECTION

Connect the **mains supply cable** to the terminal block on the back plate as follows (see connection diagram):

EARTH (Green / Yellow)	⊕
NEUTRAL (Blue)	N
LIVE (Brown)	L

Connect the **cable from the slave lighting load** to the terminal block on the backplate as follows (see connection diagram):

EARTH (Green/Yellow)	⊕
NEUTRAL (Blue)	N
SWITCH LIVE (Brown)	L1

- Ensure that all connections are secure.
- Connect the 3 way PIR plug, by pushing the plug and socket inside the floodlight together until they lock. DO NOT FORCE. THE PLUG AND SOCKET WILL ONLY FIT TOGETHER ONE WAY AROUND (See Jumper Plug diagram).
- Secure the PIR to the luminaire using the 4 fixing screws supplied (see diagram G)

6. Commissioning and Operation

Walk Test Procedure

The sensor will rotate from left to right, and tilt up or down. Adjust the sensor to point in the required direction and angle down to limit forward range as required.

The unit can be set up in daylight or at night.

Set the time adjustment to the minimum (fully anti-clockwise) and the light threshold to maximum (fully clockwise), (see diagram C).

Turn the power to the unit on. The lamp will illuminate for approximately 35 seconds. This indicates the unit is wired correctly.

The unit is in Automatic Mode when the light turns off.

If the detection area is too small for your requirements, try angling the sensor head up. This will increase the detection area. Angling the head downwards will reduce the detection area should a smaller coverage be required.

Setting Up For Automatic Operation

When walk tests are completed, the unit can be set up for Automatic Mode.

The TIME setting controls how long the unit remains illuminated following activation and after all motion ceases. (See diagram C, the time adjustment knob is indicated by the "Clock" symbol).

The minimum time (fully anti-clockwise) is approx. 3 seconds, whilst the maximum time (fully clockwise) is approximately 18 minutes. Set the control to the desired setting between these limits.

The DUSK control determines the level of darkness required for the unit to start operating. (See diagram C). The DUSK adjustment knob is indicated by the "Moon" and "Sun" symbols).

Set the light threshold to maximum (fully clockwise/Sun end), then turn the control anticlockwise about three quarters of the way round to the Moon end. This will give operation after DUSK approximately.

For a more accurate setting of the DUSK control turn it fully anti-clockwise (Moon end) and leave for at least 20 seconds for the unit to settle.

When the ambient light level reaches that required for DUSK, adjust the DUSK control a small amount clockwise pausing to try to get the unit to detect and turn the lights under control ON by moving a hand slowly backwards and forwards across the front of the detector lens for around 5 seconds.

Continue to turn the control small amounts in a clockwise direction, stopping after each adjustment to try to get the unit to detect as above.

Eventually detection will occur and the DUSK level is now set as required.

7. Masking The Sensor Lens

- To reduce the sensor coverage, preventing detection in unwanted areas, mask the sensor lens using the lens mask sticker supplied (see diagram D).
- The top section of the lens covers long range detection, the bottom covers short range.

Similarly the left and right lens sections cover the left and right detection area respectively.

- Mask the sensor to suit your installation.

8. Manual Override Mode

• The light can be switched on for longer time periods by use of the Manual Override Mode. This can be activated by using the internal wall switch or circuit breaker. Switch the internal wall switch once (OFF/ON) within 1.5 seconds.

• The unit will now illuminate continuously for 6 hours, or until switched back into Auto Mode.

• To return to Auto Mode, switch the internal wall switch OFF and then back ON again within 1.5 seconds.

• The unit will return to its Auto Mode and will operate as set up after the walk test procedure.

9. Detector Head Adjustment

The detector head can be panned 90° to the right and 90° to the left. It also can be tilted down 150°.

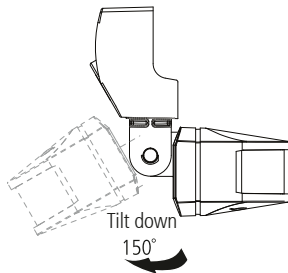
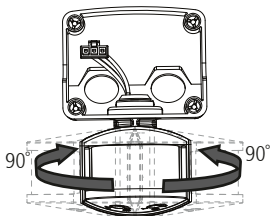

10. Accessing Terminals After Installation

This may be necessary to add further lighting for instance and the following procedure for removing the unit from its backplate should be followed:-

Insert the wire through the hole indicated in diagram F.

The terminals are now accessible. If adding lighting, ensure the unit's rating is not exceeded.

If you experience problems refer to Troubleshooting Guide.

If problems still exist,
do not immediately return the unit to store.

Telephone the Timeguard Customer Helpline

020 8450 0515

Qualified Customer Support Co-ordinators will be on-line to assist in resolving your query.

8

11. Troubleshooting

PROBLEM

- ❑ Possible stays ON all the time night and day.
- ❑ Lamp stays ON all the time at night, or PIR keeps activation at random for no apparent reason

SOLUTION

Check wiring connections. Wires to L and L1 terminals may be transposed.

The unit may be suffering from false activation. Cover the sensor lens completely with black PVC tape. This will prevent the sensor from "seeing" anything. If the unit now switches off after the set time duration and does not re-activate, this indicates that the problem was caused by false activation. The problem may be solved by slightly adjusting the direction/angle of the sensor head (see previous section). If however, the unit continues to remain ON or the operate randomly the unit is faulty and should be replaced.

❑ PIR sensor will not operated at all.

You may not be allowing the unit time to complete it's warm-up period. Stand well out of the detection range and wait (the warm-up period should never exceed 5 minutes).

Occasionally, winds may activate the sensor.

Sometimes passages between buildings etc. can cause a "wind tunnel" effect.

Ensure the unit is not positioned so as to allow detection of cars/people using public thoroughfares adjacent to your property.

Ensure that the unit is mounted securely, even the slightest movement can result in a false detection.

Check that the power is switched ON at the circuit breaker/internal wall switch.

Turn OFF the power to the unit and check the wiring connections as per the diagram (see diagram E).

Ensure no connections are loose.

Check the bulb. If the bulb has failed, replace (do not hold bulb directly with fingers, use a tissue or clean dry cloth).

Ensure that the bulb is seated correctly in the bulbholder.

❑ The PIR sensor will not operate at night.

Refer to section 4 for DUSK control adjustment.

❑ Unit activates during the daytime.

Refer to section 4 for DUSK control adjustment.

❑ PIR coverage is poor/ sporadic.

Unit may be poorly located. See previous section- "Selecting The Location" and re-locate the unit.

❑ Detection range varies from day to day.

PIR sensors are influenced by climatic conditions. The colder the ambient temperature, the more effective the sensor will be. You may need to make seasonal adjustments to the sensor head position to ensure trouble-free operation all year round.

3 Year Guarantee

In the unlikely event of this product becoming faulty due to defective material or manufacture within 3 years of the date of purchase, please return it to your supplier in the first year with proof of purchase and it will be replaced free of charge.

For years 2 and 3 or any difficulty in the first year, telephone the helpline on 020 8450 0515 .

Note: A proof of purchase is required in all cases. For all eligible replacements (where agreed by Timeguard) the customer is responsible for all shipping/postage charges outside of the UK. All shipping costs are to be paid in advance before a replacement is sent.



If you experience problems, do not immediately return the unit to the store. Telephone the Timeguard Customer Helpline;

HELPLINE

020 8450 0515

or email helpline@timeguard.com

Qualified Customer Support Co-ordinators will be on-line to assist in resolving your query.



A **theben** Group Company

For a product brochure please contact:

Timeguard Limited.
Victory Park, 400 Edgware Road,
London NW2 6ND

Sales Office: 020 8452 1112
or email csc@timeguard.com

www.timeguard.com