

### EVENTUALLY, YOU MAY WANT TO REPLACE THIS PRODUCT:

Regulations require the recycling of Waste from Electrical and Electronic Equipment (European "WEEE Directive" effective August 2005—UK WEEE Regulations effective 2nd January 2007). Environment Agency Registered Producer: WEE/ GA0248QZ.

WHEN YOUR PRODUCT COMES TO THE END OF ITS LIFE OR YOU CHOOSE TO REPLACE IT, PLEASE RECYCLE IT WHERE FACILITIES EXIST - DO NOT DISPOSE WITH HOUSEHOLD WASTE.

### LAMP REPLACEMENT:

The light source is designed to last the lifetime of the luminaire.

The light source contained in this luminaire shall only be replaced by the manufacturer, service agent or a similar qualified person.

**CAUTION, RISK OF ELECTRIC SHOCK.**



### INDUSTRIAL BATTERIES:

Within certain products Eterna Lighting Ltd places lead acid, lithium ion, nickel cadmium & nickel metal hydride batteries on the market. Industrial batteries are subject to waste regulation under the Waste Batteries and Accumulators Regulations 2009 and should be disposed of responsibly. Purchasers may be able to dispose of their waste industrial batteries locally via legitimate licensed trade waste contractors. Eterna is obliged to take back, free of charge and within a reasonable time, waste industrial batteries of the same chemistry supplied to a Purchaser, for treatment and recycling and is required to do this in any calendar year new industrial batteries are placed on the market. In certain circumstances, this may include batteries not originally supplied by Eterna. If any Purchaser requires Eterna to take back Industrial batteries, they should write to the Operations Director, Eterna Lighting Ltd, Huxley Close, NN8 6AB, who will then advise on the necessary arrangements for the receipt, proper treatment and recycling of, the waste industrial batteries.

### BATTERY REPLACEMENT:

If after routine operation check, the lamp does not remain lit for the three hour period, a new battery pack may be required.

01. Switch off the electricity at the mains (both permanent live and switch live) and allow batteries to fully discharge then reconnect to supply and allow charging for 24 hours.
02. Test again for 3 hours, if light does not remain lit, then change the battery pack as follows:
03. Remove the diffuser.
04. Remove the battery case from the gear tray, remove the battery and cut the wires.
05. Write current date on the new battery pack and fit a new battery with a suitable connector.
06. Refit gear tray and diffuser.
07. Restore power and allow charging for 24 hours.
08. Perform full operation check and update test record.

### REPLACEMENT BATTERY TYPE:

3.2V 1500mAh Lithium

### CLEANING:

Clean this fitting only with a soft dry cloth.

Do not use any chemical or abrasive cleaners.

### IF YOU EXPERIENCE PROBLEMS:

If you believe your product is defective, please return it to the place where you bought it. Our Technical Team will gladly advise on any Eterna Lighting product, but may not be able to give specific instructions regarding individual installations.

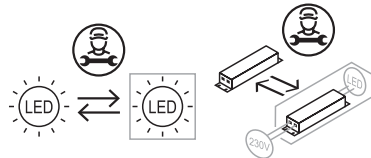

See website for more information on reusability and recycling



# Eterna

Everyday Lighting For Professionals

## INSTALLATION INSTRUCTIONS

### A guide for qualified electricians

## 3 HOURS DURATION IN EMERGENCY MODE



**Pack contents:**  
1 x Base  
1 x Diffuser  
1 x Maintenance check record

Model:

# SQPRISEM3 / SQOPALEM3 CIRPRISEM3 / CIROPALEM3

### IP65 Emergency LED Utility Fitting

These instructions are provided as a guideline to assist you.

**PLEASE READ THESE INSTRUCTIONS BEFORE INSTALLATION  
AND RETAIN FOR FUTURE REFERENCE**

Email: [sales@eterna-lighting.co.uk](mailto:sales@eterna-lighting.co.uk) / [technical@eterna-lighting.co.uk](mailto:technical@eterna-lighting.co.uk)

Visit our website: [www.eterna-lighting.co.uk](http://www.eterna-lighting.co.uk)

Made in China

## READ THIS FIRST:

Check the pack and make sure you have all of the parts listed on the front of this booklet. If not, contact the outlet where you bought this product.

This product must be installed by a competent person in accordance with the current building and IEE wiring regulations.

As the buyer, installer and/or user of this product it is your own responsibility to ensure that this fitting is fit for the purpose for which you have intended it. Eterna Lighting cannot accept any liability for loss, damage or premature failure resulting from inappropriate use.

This product is designed and constructed according to the principles of the appropriate British Standard and is intended for normal domestic service. Using this fitting in any other environments may result in a shortened working life, for example where there is prolonged periods of use or higher than normal ambient temperatures such as lighting public or shared spaces or in nursing /care home facilities.

Switch off the mains before commencing installation and remove the appropriate circuit fuse or lock off MCB.

Suitable for outdoor use.

This product is suitable for use in living areas, Bathroom Zone 2 and outside of zones.

**If being fitted in a bathroom a 30mA RCD must be used.**

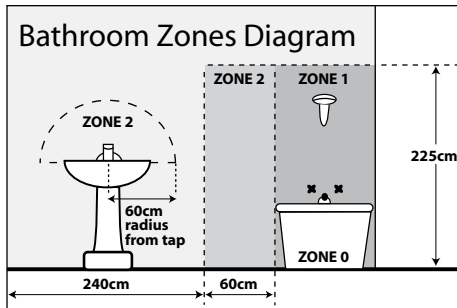

This product is designed for permanent connection to fixed wiring: this must be a suitable circuit (protected with the appropriate MCB or fuse).

This product is suitable for installation on surfaces with normal flammability e.g. wood, plasterboard and masonry. It is not suitable for use on highly flammable surfaces (e.g. polystyrene, textiles).

Before making fixing hole(s), check that there are no obstructions hidden beneath the mounting surface such as pipes or cables.

The chosen location of your new fitting should allow for the product to be securely mounted (e.g.

to a ceiling joist) and safely connected to the mains supply (lighting circuit).

When making connections ensure that the terminals are tightened securely and that no strands of wire protrude. Check that the terminals are tightened onto the bared conductors and not onto any insulation.

This product must be connected to earth termination.

This product is not intended to be used by children and persons with sensory, physical and/or mental impairments that would prevent them from using it safely.

You are advised at every stage of your installation to double-check any electrical connections you have made. After you have completed your installation there are electrical tests that should be carried out, these tests are specified in the current IEE wiring and building regulations.

The batteries supplied with this fitting are a consumable part and therefore may be outside of any warranty offered.

## INSTALLATION:

Isolate mains and lock off.

Choose the location of your new fitting giving consideration to all of the points listed above.

- 01) Unscrew gear tray screw and allow the gear tray to rest on its hinge.
02. Drill holes in the back of your fitting for your fixing screws, take care and drill gently to ensure a clean hole through. Use a drill bit sized appropriately to your fixing screws (not supplied).
03. Using the back of your fitting as a template, mark the position of your fixing holes on your mounting surface.
04. Prepare the holes in your mounting surface as appropriate for your fixings.
05. Pierce the rubber grommet in the back of your fitting making a hole just large enough to make a tight fit around the incoming mains cable.
06. Thread the cable through the grommet and offer the fitting to the ceiling / wall.
07. Secure the fitting in place. Note if protection against ingress of moisture is required, the heads of screws must be covered with a silicone or similar sealant.
08. Check that the grommet is still correctly fitted in the cable entry hole and around the incoming cable.
09. Make the electrical connections according to the symbols, adjacent to the connector block, Brown to live (L) Blue to neutral (N) and earth green & yellow (E).
10. Mark the current date on the battery pack.
11. Connect the battery plug to the socket on the driver.
12. Replace the diffuser and tighten securely making sure the gasket is correctly fitted in place.
13. Restore the power and check fitting is working correctly. A green LED light should always be present indicating the fitting is charging.

**NOTE: For non-maintained operation, remove link wire from L and L1.  
For switched operation, remove link wire and make a switched supply into L1.**

## OPERATION CHECKS:

Periodic testing should be carried out to ensure emergency lighting is operating correctly. Interruption of the supply, causing the fitting to be energised from the battery, should be carried out by the operation of a local keyswitch or other isolation device. During this period all fittings should be examined visually to ensure that they are functioning correctly. At the end of the test period the supply shall be restored and all indicator lamps or devices checked to ensure that the normal supply has been restored.

### DAILY:

Visual inspection of the battery charge LED.

### EACH MONTH:

Isolate the power supply for a period sufficient to ensure that each lamp is illuminated. Endorse the test record form supplied.

### ONCE EACH YEAR:

Isolate the power supply and check that the light is still illuminated after 3 hours. Endorse the test record form.

Because of the possibility of a failure of the normal lighting supply occurring shortly after a period of testing of the emergency lighting system or during the subsequent recharge period, all full duration tests shall wherever possible be undertaken preceding time of low risk to allow for battery recharge.

**NOTE: please keep this instruction booklet and the test record in a safe place. A fire officer or other authorised person may want to see your record of inspection and testing.**



LED LAMP SPECIFICATIONS:	
Luminaire lumens (opal)	<b>1400 lm</b>
Luminaire lumens (prismatic)	<b>1600 lm</b>
Lumens from chip (no diffuser)	<b>1750 lm</b>
Rated Wattage	18W
Rated luminous flux (Opal)	1350 lm
Rated luminous flux (Prismatic)	1550 lm
Nominal life time of the lamp	35,000 hrs
Colour temperature	4000K
Number of switching cycles before premature lamp failure	15,000
Warm-up time up to 60% of the full light output	Instant full light
Dimmable	No
LED array dimensions SQUARE	(L) 215 x (H) 215mm
LED array dimensions CIRCLE	240mmØ
Nominal beam angle	120°
Rated power	18W
Rated lamp lifetime	35,000 hrs
Displacement factor	Opal: 0.95 Prismatic: 0.90
Lumen maintenance factor at end of nominal life	≥0.70
Starting time	<0.1s
Colour rendering	80 Ra
Colour consistency	Within 6 step Macadam ellipse
Rated peak intensity	520cd
Rated beam angle	120°
Voltage / Frequency	240V~50Hz
Not suitable for accent lighting	

