



2 Pole Plastic Enclosed Changeover Switches (IP65)

Technical Data



- Under load operation
- Earth terminal included
- Captive +/- terminal screws
- Padlockable in OFF position (up to 3 padlocks)
- Lid interlocked with switch in position 1 and 2
- IP65 rating in all the enclosures
- Manufactures to IEC60947-3

Data		Part Number				
		ERSPCO252	ERSPCO322	ERSPCO402	ERSPCO632	ERSPCO1002
Electrical Ratings (According to IEC 60947-3)						
AC Rated thermal current I _{th} (40°C)		25A	32A	40A	63A	100A
Rated insulation voltage U _i (V)		500	690	690	690	690
Rated impulse withstand voltage U _{imp} (kV)		6	6	8	8	8
AC Rated operational current I_e (A)						
Rated voltage	Utilization category	I _e	I _e	I _e	I _e	I _e
415 VAC	AC21A	25A	32A	40A	63A	100A
Connection capacity						
Rigid cable (Cu) (mm ²)		2x4	2x6	2x10	16x25	35x50
Flexible cable (Cu) (mm ²)		2x2,5	2x4	2x6	10x16	16x35

For any further comments or assistance please contact:

eris-eu.com



Dimensions

ERSPCO252, ERSPCO322 and ERSPCO402

175 H x 151W x 95D

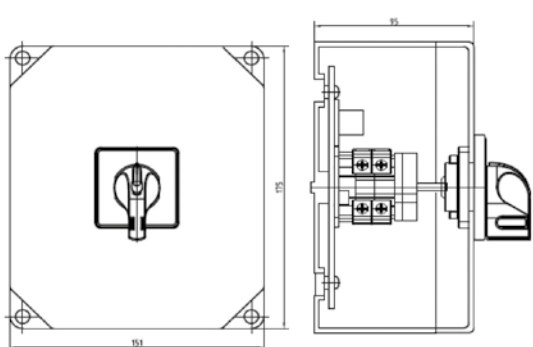

ERSPCO632

180 H x 182W x 137D

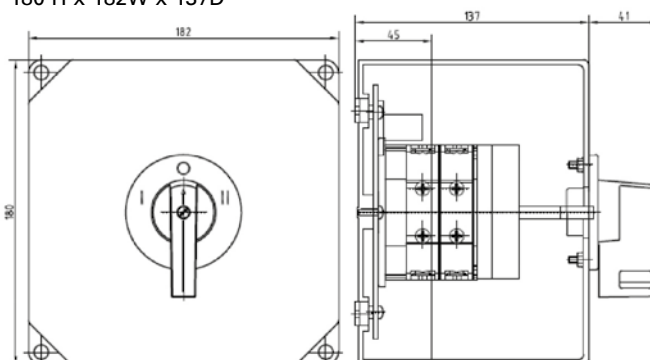

ERSPCO1002

254 H x 180W x 137D

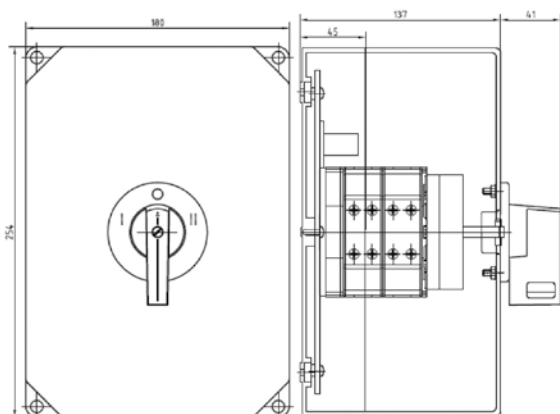

Electrical Drawing

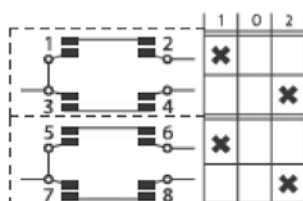
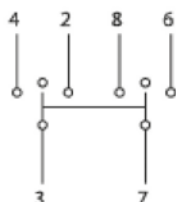
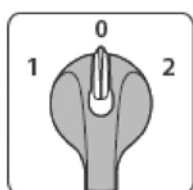

For any further comments or assistance please contact:

eris-eu.com

Dimensions

ERSM324

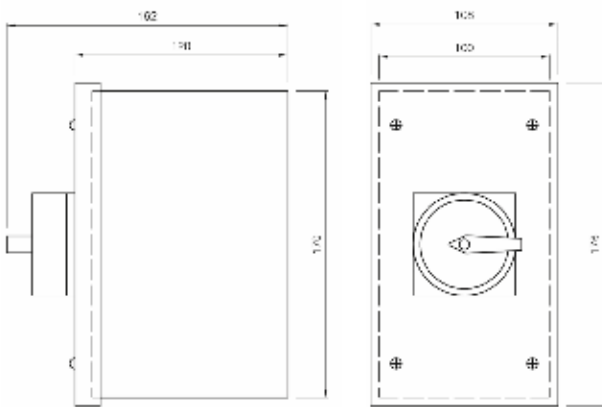

ERSM634

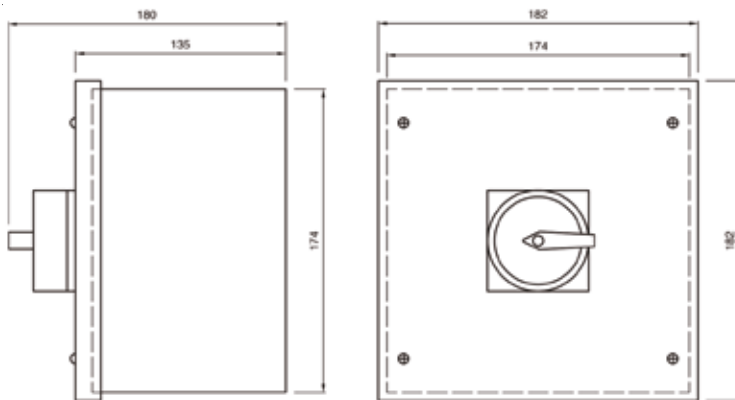

Terminal Configuration

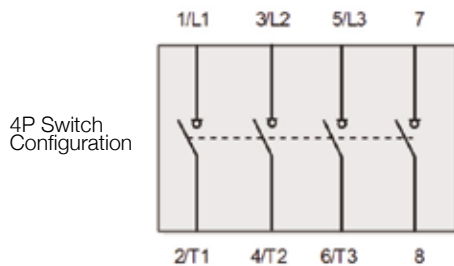

For any further comments or assistance please contact:

eris-eu.com