

# Emergency Twin Spot 2x 3W LED



## Installation Instructions



**Please read these instructions carefully before installation**

Leave a copy for the user/maintenance engineer for future reference

### Important Safety Information

- It is recommended that this luminaire is installed, inspected and maintained by a qualified electrician.
- Installation should be carried out in accordance with the latest edition of the IET Wiring Regulations (BS 7671) and the latest Building Regulations. If in doubt, consult a qualified electrician.
- These products are designed for connection to a 220-240V~50/60Hz supply.
- Before commencing any installation or maintenance work, ensure that the electrical mains supply is isolated and circuit fuses are removed or switched off.
- All electrical connections must be tight with no loose strands including factory made connections.
- Ensure that there is adequate free air ventilation around the luminaire.
- Please note the IP rating of this luminaire when deciding the location for installation.
- This luminaire is suitable for indoor and outdoor use.
- This is a Class I construction luminaire.
- This luminaire is suitable for use in ambient temperatures of 0°C to +50°C.
- MCBs may require to be uprated to allow for increased initial inrush current.
- Do not carry out any insulation resistance tests with the luminaire connected to the circuit.
- The LED light source fitted in this product is non replaceable. The whole luminaire must be replaced when the LED reaches the end of its life.

### Emergency Twin Spot

Electrical Classification

Class I

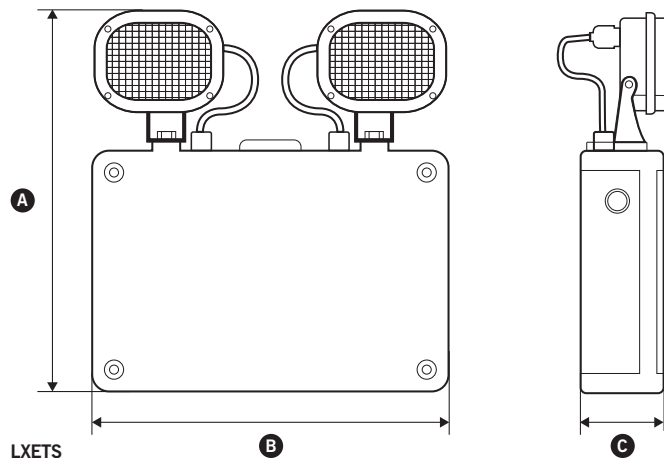

### Technical Specifications

Part No.	Description	Wattage	Measurement A x B x C	Lumen Output	IP Rating	CRI	Class Rating	Colour Temperature
LXETS	Emergency Twin Spot LED	6W	300x280x70mm	500Lm	IP65	>80	Class I	6000K

# Important Installation Information

Select a suitable mounting position and use the correct fixings for the type of surface. Ensure that there is adequate free air ventilation around the luminaire at all times. Do not install this product onto damp or newly plastered walls or ceilings. Always switch off and isolate the mains power supply before commencing installation.

1. Remove the four corner screws and the front cover from the base to access the luminaire.
2. Choose the mounting surface and mark the position of the fixing points for the luminaire base. This luminaire is suitable for mounting in any orientation, but it is recommended that a flat and level surface is used for installation
3. Select a mains cable entry point on the base of the luminaire. Entry points are available through the rear and side of the housing. Drill to a suitable size for cable entry and ensure that appropriate grommets or compression couplings are used to maintain the IP65 rating where required.
4. Drill the fixing points to a size to suit the fixing screws and mount the luminaire base to the surface. Ensure that the fixing holes in the luminaire are sealed to maintain the IP65 rating.
5. Feed the mains supply cable through the cable entry point and connect to the terminal block as shown in **Fig.1**. Ensure that the correct polarity is observed.
6. Connect the emergency battery pack lead to the PCB by connecting the socket to the plug marked 'BATT' on the PCB ensuring correct orientation.
7. Complete the installation date on the label adjacent to the battery pack.
8. Refit the front cover to the base using the four corner screws and ensure that there is a good seal to maintain the IP65 rating.
9. Rotate and angle the two lamp heads to the desired direction to suit the installation. The retaining bolts and screws on the lamp heads may need to be loosened to allow rotation. Ensure that they are re-tightened to secure the installation.
10. Reconnect the mains power supply, test for satisfactory operation and check that the green LED charge indicator illuminates.
11. The batteries should be charged for a minimum of 24 hours before carrying out a full discharge test to check that they are charging correctly and that the maintained 3 hour duration is being achieved.
12. The emergency luminaire test record should be completed as required and left with the end user.

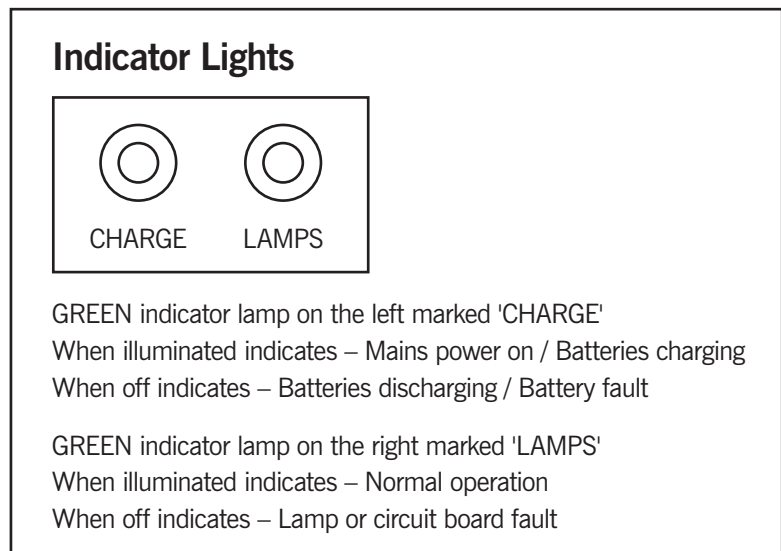
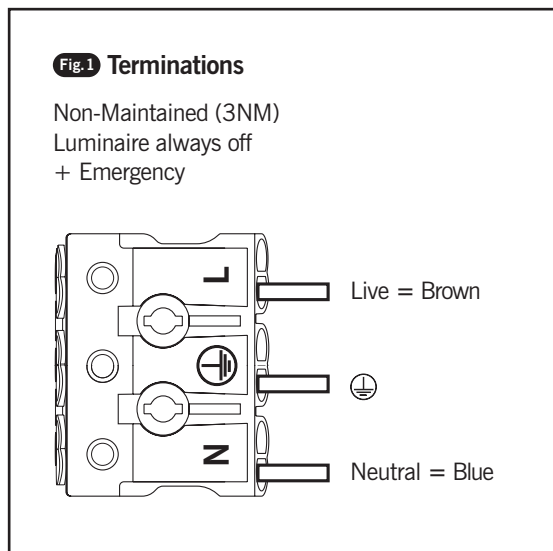

## Emergency Luminaire Connection and Testing

1. The Emergency luminaire requires an unswitched live supply to ensure that the batteries remain charged.
2. Ensure that the battery cells supply cable is connected to the Emergency module before mains power is restored.
3. Once installed, the batteries must be charged for a minimum of 24 hours before carrying out a full discharge and commissioning test to check that they are charging correctly and that the maintained 3-hour discharge duration is being achieved. The date should be noted on the battery. The Green LED Indicates that the batteries are charging.
4. Emergency luminaires should be routinely inspected and tested in accordance with current **BS 5266** guidelines. Refer to **BS 5266 & BS EN 50172** for full Emergency Lighting requirements and testing procedures
5. A log report must be completed and kept for the periodic test procedure. A copy of the Emergency test record sheet is included with this product. Further copies can be requested at [sales@luxna.co.uk](mailto:sales@luxna.co.uk)
6. A completed copy of the Emergency test record sheet must accompany any product returned to the manufacturer.

**Batteries:** The battery cells inside an emergency product are a consumable replaceable item. The batteries have a normal operating designed service life of 4 years and must be replaced in a timely manner to ensure that the integrity of the emergency lighting system is maintained. The battery cells actual service life can be shortened by several variable factors including (but not limited to): Type of installation environment, Room temperature, Number of charge/discharge cycles, power supply interruptions etc. The product should be tested and maintained regularly according to the details within the instruction manual. Should the battery cells fail to provide the minimum rated discharge duration of 3 hours at any time during the products service life, they must be replaced. **Emergency luminaires must not be installed in areas where the ambient area temperature is above or below the recommended operating temperature range 0°C to +50°C**

**Warranty:** This product is protected by guarantee in the UK and EU for a period of 5 years warranty from the date of purchase against any defects in materials or workmanship. Should this product fail during the warranty period it will be repaired or replaced with the same or equivalent product free of charge, subject to providing the original receipt/invoice or proof of the original date of purchase and return of the faulty unit. If in our sole discretion, we are unable to repair or replace a defective product, we will refund the purchase price of the product. The warranty is invalid if in our judgment the product fails due to incorrect installation not conforming to our product instructions or installation within an improper working environment. The warranty will not apply if the product fails due to damage in storage, shipment, accident or misuse. Modification to the product in any way or removal of the batch number will void the warranty. Luxna Lighting does not accept responsibility for any installation, labour or travel costs which may be associated with the replacement or return of any faulty products. Our maximum liability under the terms of this warranty is limited to the purchase price of the product. Your statutory rights are not affected. Luxna Lighting reserves the right to alter product specifications without prior notification. Terms and conditions are also subject to change without prior notice.