

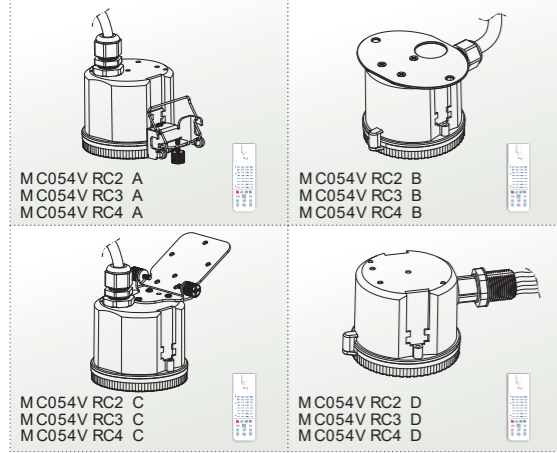

Microwave Sensor & RC Installation Instructions



FEATURE

- Sensor parameters can be conveniently set by a remote control.
- Mounting height up to 49.2 ft (15m)max. , suitable for warehouse use.
- Waterproof sensor with IP65 rating.
- Automatic dimming when used in combination with 1-10V dimmable control gears.
- Built-in adjustable daylight sensor.
- 1 - 10V interface can match up with Merrytek stand-alone daylight sensor MS01 and achieve daylight harvesting.
- Optional mounting brackets for different application.

SPECIFICATIONS

Input voltage	220-240Vac, 50/ 60Hz(AUS/ EURO) 120/ 277Vac,50/ 60Hz(USA)
Rated load (EURO/ AUS)	800W-Inductive 1E4 1200W-Resistive 1E4
Rated load (USA)	120Vac 50/ 60Hz 4A E-ballast 277Vac 50/ 60Hz 3A E-ballast
Surge current of load	50A (50% Ipeak, twidth =500uS, 277Vac full load, cold start); 80A (50% Ipeak, twidth =200uS, 277Vac, full load, cold start)
Detection area	100% / 75% / 50% / 25%
Hold time	5S/ 30S/ 1min/ 3min/ 5min/ 10min/ 20min/ 30min
Daylight sensor	5lux/ 15Lux/ 30Lux/ 50Lux/ 100lux/ 150lux/ Disable
Stand-by period	0s/ 10S/ 1min/ 3min/ 5min/ 10min/ 30min/ ∞
Stand-by dimming level	10% / 2 0% / 3 0% / 5 0%
Sensor principle	Microwave motion detector
Microwave frequency	5.8GHz±75MHz, 1SM w ave band
Mounting height	49.2 ft (15m) Max.
Detection angle	150° (Wall installation), 360° (Ceiling installation)
Motion detection	1.6~3.3 ft/ s(0.5~1 m/ s)
Operating temperature	-35°C~55°C
IP rating	IP65 (INDOOR USE ONLY)
Factory Setting	Detection area:75%, Hold time:5s, Stand-by Period: 0s, Stand-by dim level:10%, Daylight Sensor: Disable
Overvoltage Category	4000V
Control Type	Operating type 1.B
Software	Class A
Pollution Degree	2

GENERAL GUIDELINES FOR INSTALLATION

1. The sensor should be installed by a qualified electrician. And ensure that the electricity supply is switched off before installing or servicing the product.
2. Installation inside a glass or plastic housing will result in a reduction of detection sensitivity. Expect a reduction of approximately 20% for every 3mm of thickness.
3. Detection area will be affected by speed of motion, height of installation and volume of moving object.
4. Daylight sensor was tested on sunny environment with no lampshade. ambient lux level could be different under different weather, climate, season or environment

APPLICATION NOTICE

1. Sensors settings may need to be adjusted to match installation site, please follow below instructions or contact manufacturer.
2. The sensor is designed for indoor use only. Outdoor use for a long time may reduce the waterproof effects. The raining or wind blowing may trigger the microwave sensor even if without human motion when outdoor use.
3. The distance between any two sensors should be at least 3m to avoid interference with each other.
4. When the microwave sensor is installed in a metal lighting fixture or space with large reflector, for example a warehouse with metal roof, the microwave will be reflected and cause the lights permanently illuminated even if without motion signal. Please reduce the detection area (sensitivity) to solve the problems, or contact the microwave sensor manufacturer to provide technical support.
5. Make sure the sensor not close to or be blocked by high density material, such as metal, glass, concrete walls etc. The materials will reduce or block microwave and cause false trigger.
6. Make sure there are no fans or other vibrating objects in installation area. The movements will trigger sensor as well.

INITIALIZATION

1. ON/OFF function or 3-step dimming function:
After power on, the sensor automatically turns on light at 100% brightness. After 10sec, it completely turns off light.
During the initialization, the sensor is not able to detect movement.
2. 2-step dimming function:
After power on, the sensor automatically turns on light at 100% brightness. After 10sec, it dims the light to a low light level (set by stand-by dim level).
During the initialization, the sensor is not able to detect movement.

DETECTION PATTERN

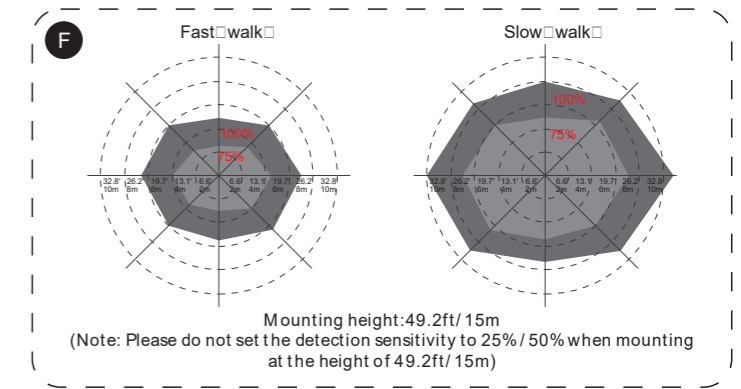
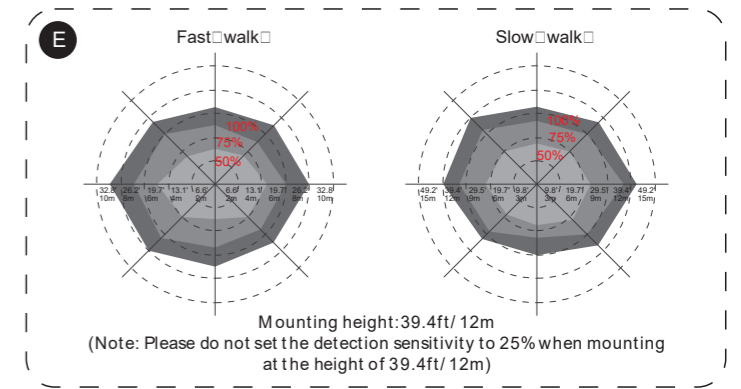
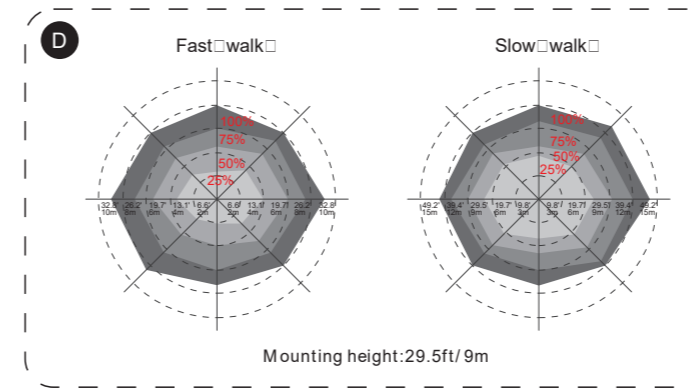
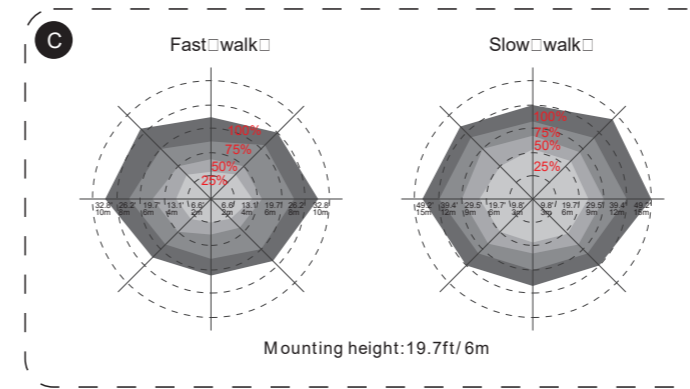

DETECTION PATTERN(FOR WALL MOUNTING)

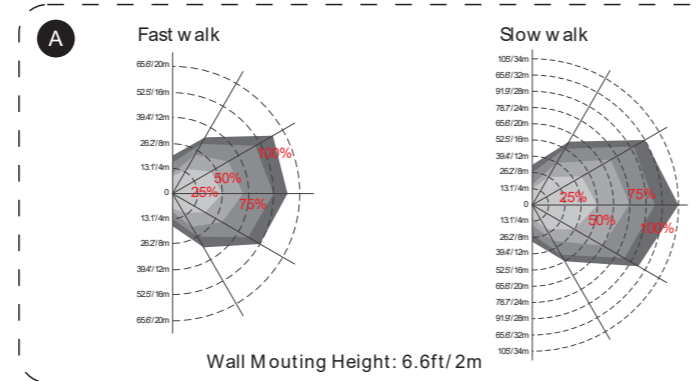

DETECTION PATTERN(FOR CEILING MOUNTING)

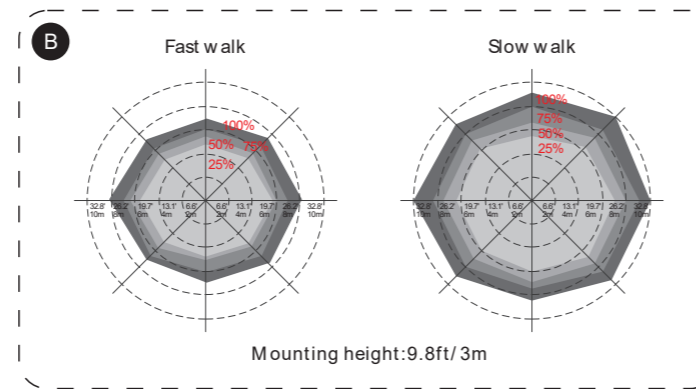

INSTALLATION

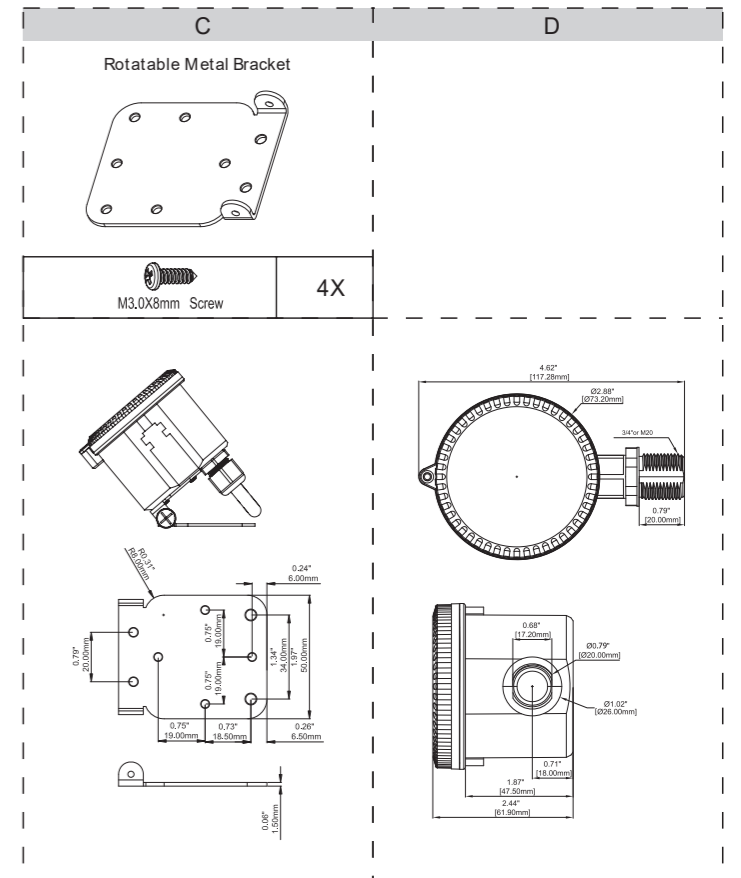
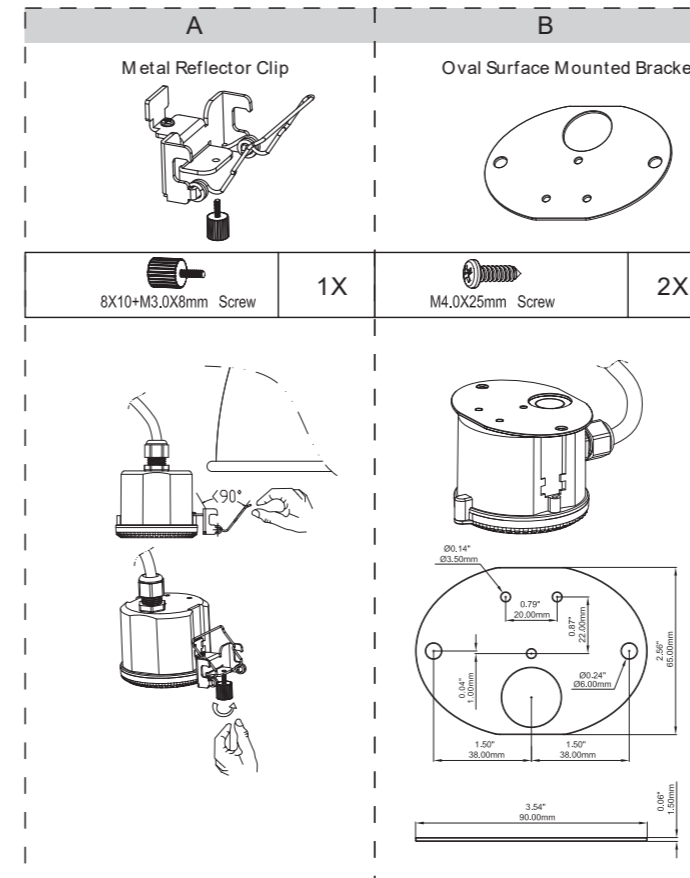

Remote Control Setting

Button	Remarks																												
ON/OFF	Press the "ON/OFF" button, the light goes to constant on/off mode, sensor is disabled. Press any button to quit from this mode and the sensor starts to work.																												
Reset	Press "Reset" button, all parameters are same as setting of factory settings.																												
Sensor motion	Press "Sensor motion" button, the light quits from the constant on/ off mode, and the sensor starts to work (The latest setting stays in validity)																												
DIM Test	Press "DIM Test" button, the 1-10 V dimming works to test whether the 1-10Vdc dimming ports are connected properly. After 2s, it returns to the latest setting automatically.																												
Override DH	Override DH: Long press >3s, sensor will quite daylight priority(MC054V RC3)/ daylight harvesting(MC054V RC4) mode, daylight threshold start to work with previous daylight value NA(MC054V RC2) DH Mode: Long press >3s, sensor move to daylight priority mode, please be sure preset daylight threshold is not "Disable" (MC054V RC3) Long press >3s, sensor will take current light level as target lux level, dim up/down load according to change of ambient light level(MC054V RC4), each time press DIM+, DIM-, target light level change is 5% NA(MC054V RC2)																												
DIM+ DIM-	Set occupancy light level in range of 50-100%, dimming level is 2% each time to press Dim+/Dim- button																												
Q1 Q2 Q3	<table border="1"> <thead> <tr> <th>Scene Options</th> <th>Detection Area</th> <th>Hold Time</th> <th>Stand-by period</th> <th>Stand-by dim level</th> <th>Daylight Sensor</th> <th>Sensitivity model</th> </tr> </thead> <tbody> <tr> <td>QS1</td> <td>100%</td> <td>5min</td> <td>10min</td> <td>10%</td> <td>30Lux</td> <td>Hs</td> </tr> <tr> <td>QS2</td> <td>100%</td> <td>10min</td> <td>30min</td> <td>10%</td> <td>Disable</td> <td>Hs</td> </tr> <tr> <td>QS3</td> <td>100%</td> <td>20min</td> <td>30min</td> <td>10%</td> <td>Disable</td> <td>Hs</td> </tr> </tbody> </table> <p>Note: Detection area / Hold time /Stand-by period /Stand-by dim level / Daylight sensor can be adjusted by pressing the corresponding button. The latest setting will stay valid.</p>	Scene Options	Detection Area	Hold Time	Stand-by period	Stand-by dim level	Daylight Sensor	Sensitivity model	QS1	100%	5min	10min	10%	30Lux	Hs	QS2	100%	10min	30min	10%	Disable	Hs	QS3	100%	20min	30min	10%	Disable	Hs
Scene Options	Detection Area	Hold Time	Stand-by period	Stand-by dim level	Daylight Sensor	Sensitivity model																							
QS1	100%	5min	10min	10%	30Lux	Hs																							
QS2	100%	10min	30min	10%	Disable	Hs																							
QS3	100%	20min	30min	10%	Disable	Hs																							
TEST 2S	Press the "TEST 2S" button can enter the test mode any time. At the mode, the sensor parameters as below: Detection Area is 100%, Hold Time is 5s, Stand-by Dim Level is 10%, Stand-by Period is 0s, daylight sensor disable. This function only for testing. Quit the mode by pressing "RESET" or any other function buttons.																												
HS LS	Press "HS" button to set the detection area to be high sensitive. Press "LS" button to set the detection area to be low sensitive. The adjustment bases on the "Detection Area" parameter you set.																												
Daylight Sensor	Set up daylight threshold: 5Lux/15Lux/30Lux/50Lux/100Lux/150Lux/ Disable.																												
Stand-by period	Set up stand-by time: 0S/10S/1min/3min/5min/10min/30min/+∞																												
Hold time	Set up hold time: 5S/30S/1min/3min/5min/10min/20min/30min																												
Stand-by dim level	Set up stand-by dim level: 10%/20%/30%/50%																												
Detection Area	Set up detection area: 25%/50%/75%/100%																												
Remote Distance	Toggle button can set the remote distance of remote control and sensor.																												

As the control angle of the Infrared Remote Control is fixed (15°), if sensors are installed too close to each other, settings of both sensors will be configured. Please refer to the below chart for the distance of the installation of the sensor:

Mounting height	Distance between sensors
49.2'/15m	16.4'/5m
39.4'/12m	13.1'/4m
29.5'/9m	13.1'/4m
19.7'/6m	11.5'/3.5m

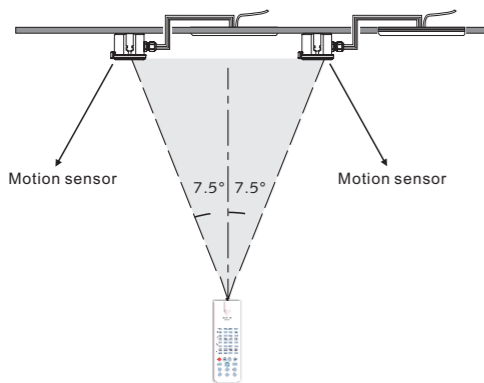

Unique design of infrared transmitting device

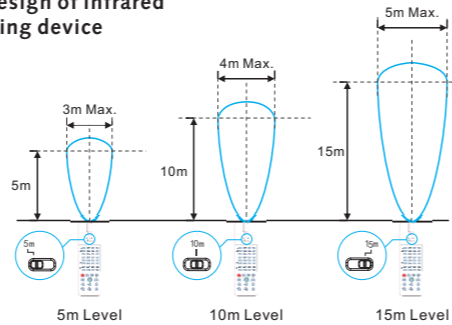

Note:

This equipment has been tested and found to comply with the limits for a Class B digital device, pursuant to part 15 of the FCC Rules. These limits are designed to provide reasonable protection against harmful interference in a residential installation. This equipment generates, uses and can radiate radio frequency energy and, if not installed and used in accordance with the instructions, may cause harmful interference to radio communications. However, there is no guarantee that interference will not occur in a particular installation. If this equipment does cause harmful interference to radio or television reception, which can be determined by turning the equipment off and on, the user is encouraged to try to correct the interference by one or more of the following Measures:

- Reorient or relocate the receiving antenna.
- Increase the separation between the equipment and receiver.
- Connect the equipment into an outlet on a circuit different from that to which the receiver is connected.
- Consult the dealer or an experienced radio/TV technician for help.

WIRING

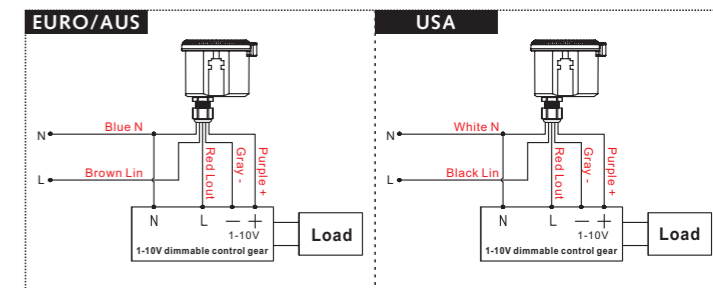
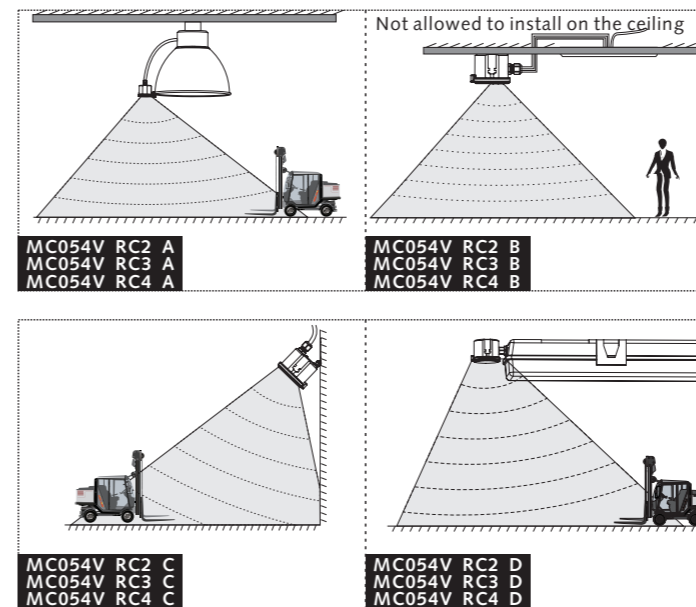

NOTE:

- 1, Lord bushing of the torque is 2.5NM, Torque of nut is 2.5NM.
- 2, The sensor is designed for connect one load only. Connect more than one loads may damage the sensor.
- 3, Switch on and off power 3 times in 2sec to override sensor function, Light can only be turned on and off manually; Power off and on 1 time to recover sensor function.



CAUTION - High Voltage -

Disconnect power supply before servicing.

FAQ

Question	Cause	Remedy
The load will not illuminate.	Incorrect daylight sensor setting selected.	Adjust setting.
	Load has failed.	Replace load.
	Power is switched off.	Switch on.
The load is permanently illuminated. (SEE NOTE1)	Continuous movement in the detection area.	Check detection area setting.
	The lamp (containing sensor) is installed in an area too close to reflective surfaces, i.e. metal, glass or concrete walls.	1, Make sure installation area suitable with at least 39.4 inches(100cm) space between lamp and surrounding reflective surfaces. 2, Reduce sensitivity (detection area).
The load will not illuminate despite movement.	Speed of moving object is not in the range of 1.6~3.3ft/s(0.5~1m/s) or the detection radius is too small.	Check detection area setting.
The remote control is not working.	The battery on the remote control is run out.	Change the battery.
	The remote control is not aligned with sensor.	Change the remote angle.

NOTE1

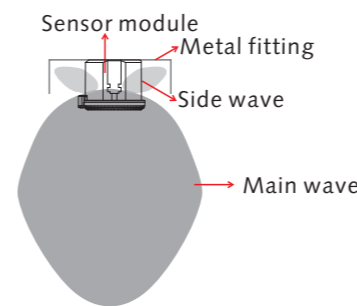

Microwave detection includes two parts called main wave and side wave. Main wave normally detects the motion signal. Side wave does not effect motion detection but might disturb main wave if the microwave motion sensor is built-in a sealed metal luminaire as microwave can not pass through metal.

When the microwave module is built into a metal lighting luminaire or installed in a sensor near a wall, the side wave will be reflected by the metal base or the wall. It can disturb the main wave. As the result of this, the microwave motion sensor might not perform optimally. Reducing the detection sensitivity or the side wave will help to solve such problems.

FCC Caution:

Any Changes or modifications not expressly approved by the party responsible for compliance could void the user's authority to operate the equipment. This device complies with part 15 of the FCC Rules. Operation is subject to the following two conditions:

- (1) This device may not cause harmful interference.
- (2) this device must accept any interference received, including interference that may cause undesired operation.

IC RSS warning:

This device complies with Industry Canada licence-exempt RSS standard (s). Operation is subject to the following two conditions:

- (1) this device may not cause interference
- (2) this device must accept any interference, including interference that may cause undesired operation of the device.

Le présent ariel est conforme aux CNR d'Industrie Canada licables aux ariels radio exempts de licence.

L'exploitation est autorisée aux deux conditions suivantes:

- (1) l'areil ne doit pas produire de brouillage, et
- (2) l'utilisateur de l'appareil doit accepter tout brouillage radioélectrique subi, même si le brouillage est susceptible d'en compromettre le fonctionnement.

LUXNA
LIGHTING

www.luxna-lighting.com

Merrytek Technology Co.
www.merrytek.com

Issue: LXLBSV2.121