

QSPOT EMERGENCY STANDALONE

Q-SPOT-1W/3H/L

QVIS[®]
LIGHTING & SECURITY



Q-DRIVE

Driver as Standard

EPISTAR

LED's inside

TECHNICAL DRAWINGS

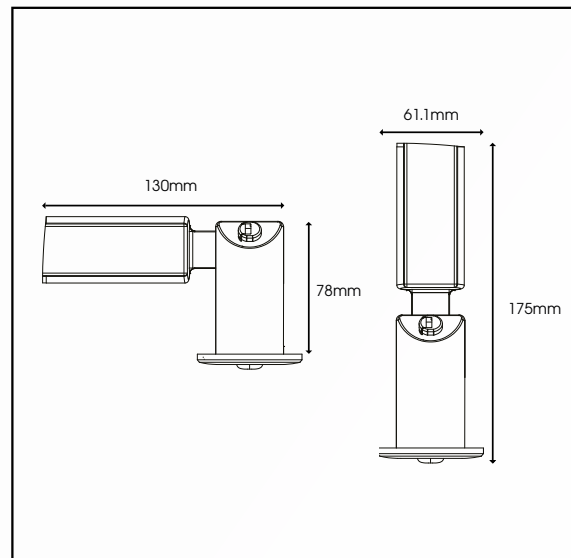

Specification	STANDALONE
System Power	1W
Driver Manufacturer	Q-Drive
LED Chipset	Epistar
IP Rating	IP20
Lumen Output	135Lm
Battery	LiFePO4 3.2V 1500mAh
Emergency Time	3 hours
Operating Mode	Maintained/Non-maintained
Testing	Manual Testing
Battery Type	Lithium Iron Phosphate
Colour Temperature	6500K
Input Voltage	VAC-200-240
Dimensions	175mm x 61.1mm
MacAdam Step	2.8
Lifetime	50,000 hours, L70-B10 (Ta 25 °C)
CE Standards	EN60598-1, EN 60598 2-22, EN62493, EN55015, EN61547, EN61000-3-2, EN61000-3-3, EN62722-1, EN62722-2-1 and EN50581
CE Directives	LVD, EMC, ERP & RoHS

* Warranty terms and conditions apply

EMERGENCY RANGE