



Model: Ei408

Switched Input Module

Battery Powered
For use with RF Alarms and Bases



Contains vital information on the product's operation and installation. Read and retain carefully. If you are just installing this product **the manual MUST be given to the householder.**

1. INTRODUCTION

The Ei408 is a battery powered RF Module that accepts an input from a set of Volt-Free switched contacts (e.g. flow switch contacts on a sprinkler system).

On receipt of a switched input, the Ei408 sends out a RF alarm signal to trigger all other RF alarms/bases in the system into alarm.

2. INSTALLATION

It is recommended that you install all other RF devices that will form part of the system before installing the Ei408 Module.

Note:

All RF units should be located in their final positions before House Coding is carried out.

The Ei408 should not be mounted close to any metal objects, metal structures or fitted to a metal back-box.

1. Remove the front plate of the Ei408 by unscrewing the two screws and then fix the back-box to a solid surface using the screws provided. (Do not recess mount the back-box).
2. Neatly run wiring from the Volt-Free switched contacts that will be used to trigger the Ei408 through one of the knockouts in the back-box and connect to the terminal block as shown in Figure 1.
3. Switch on the built-in battery by sliding the yellow battery switch to the "on" position (see Figure 2).

4. Press and hold the House Code button (shown in Figure 2) until the red light on the front plate of the Ei408 illuminates solidly. As soon as the light illuminates, release the House Code button. The red light should start to flash slowly (this indicates that the Ei408 is sending out its own unique House Code signal).

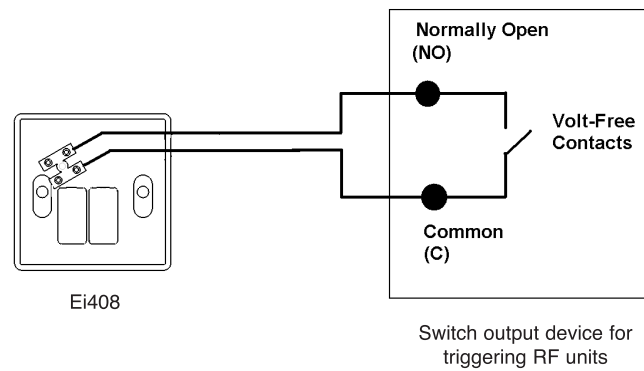

Figure 1

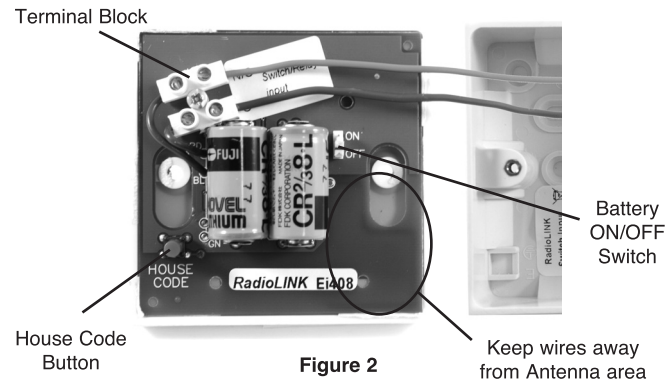

Figure 2

5. Screw the front plate back onto the back-box.
6. As quickly as possible put all other RF devices that are part of the system into House Code mode (see individual instruction leaflets). This must be done within 15 minutes of putting the Ei408 into House Code mode (step 4 above).

In House Code mode, all the RF devices will 'learn' and memorise each others unique House Code. Once House Coded, a RF device will only respond to other RF devices that it has in its memory.

7. Check that the number of amber light flashes (for RF bases) or blue light flashes (for RF alarms) corresponds to the number of RF devices in the system. For example, with 3 Ei168RC RF bases and 1 Ei408 Module in the system there should be 4 amber light flashes on each Ei168RC base (**Note:** The red light flashes from the Ei408 do not relate to the number of RF devices. The flashes simply show that it is sending out its own unique House Code).

8. Remove the Ei408 from House Code mode by unscrewing the front plate and then pressing and holding the House Code button until the red light illuminates solidly. As soon as it illuminates solidly, release the House Code button. The red light should stop flashing. Re-fit the front plate back onto the back-box. (Note: The Ei408 will automatically exit House Code mode after 15 minutes from it initially being put into House Code mode, so this step may not be required).

9. Remove all other RF devices from House Code mode (see individual instruction leaflets).

All RF devices will automatically exit House Code mode after either 15 or 30 minutes (depending upon device). However, if left in House Code mode for these periods, problems could occur if a nearby system is being House Coded at the same time (i.e. two different systems could become coded together). To prevent this it is recommended that all RF devices in a system are taken out of House Code mode once it is determined that they are all coded together.

3. CHECKING AND TESTING

The Ei408 is an important alarm device and should be tested after installation and then regularly to ensure correct operation as follows.

- a) Check that the light on the front plate flashes green every 40 seconds to show that the battery power is healthy.
- b) The module should be tested regularly with the external switch device (e.g. use a test button on the external device). The light should turn red and stay on continuously for 3 seconds and then flashes red (once every 45 seconds) for 5 minutes indicating a repeat transmission of the alarm signal. (Note: after 5 minutes the RF alarm signal ceases and therefore the smoke alarms will stop alarming. This prevents the batteries in the Ei408 module from being depleted.
- c) Check that all the RF units are now in alarm. If everything is satisfactory, cancel the test. Check all the RF units are switched off. (If some or all of the alarms have not been activated, then the House Coding procedure should be repeated. If there are still some problems, see the section on "Troubleshooting".)

Low Battery

If the light flashes amber every 9 seconds this indicates that the batteries are depleted and the Ei408 may no longer be able to send an alarm signal. The unit must be removed from its location and returned for repair if still with the guarantee period, (see Sections 7 & 8 for details).

If the end of life has been reached (see "REPLACE BY" label on the side of the mounting box) dispose according to local guidelines and regulations (see label on the inside of unit).

4. TROUBLE SHOOTING RF

If, when checking the RF interconnection, some of the alarms do not respond to the Ei408 test (as outlined in section 3), then:

- (i) Ensure the Ei408 has been activated correctly and the red light has come on continuously for 3 seconds and then continues to flash red every 45 seconds.
- (ii) Ensure that there is an Alarm/Base set as a “Repeater” within a few metres of the Ei408. If Ei168RC RF Bases are being used, they are set as “Repeaters” as standard and so an additional base (with alarm) may need to be installed.
- (iii) There are a number of reasons why the radio signals may not reach all the RF units in your system (see Section 5 on “Limitations of Radio Communications”). Try rotating the units or re-locating the units (e.g. move them away from metal surfaces or wiring) as this can significantly improve signal reception.

Rotating and/or relocating the units may move them out of the range of existing units even though they may have already been House Coded correctly in the system. It is important therefore to check that all units are communicating in their final installed positions. If units are rotated and/or resited, we recommend that all units are returned to the factory settings (see their respective use and care instructions). Then House Code all units again in their final positions. The radio interconnection should then be checked again.

Clearing the House Codes:

If it is necessary at some stage to clear the House Codes on the Ei408.

- Remove the front plate of the Ei408 from the back-box.
- Slide the battery switch off. Wait 5 seconds and then slide switch back on.
- Press and hold the House Code button for approx 6 seconds, until the red light turns on, then flashes slowly. Release the button and the red light will go out.
- Re-fit the front plate to the back-box.

Note: clearing the House Codes will reset the Ei408 to the original factory settings. It will now only communicate with un-coded units (see instruction leaflets for information on how to un-code other RF devices).

5. LIMITATIONS OF RADIO COMMUNICATIONS

Ei Electronics radio communication systems are very reliable and are tested to high standards. However, due to their low transmitting power and limited range (required by regulatory bodies) there are some limitations to be considered:

- (i) Radio equipment, such as the Ei408, should be tested regularly to determine whether there are sources of interference preventing

communication. The radio paths may be disrupted by moving furniture or renovations, and so regular testing protects against these and other faults.

- (ii) Receivers may be blocked by radio signals occurring on or near their operating frequencies, regardless of the House Coding.

6. END OF LIFE

The Ei408 is designed to last 10 years in normal use. However the unit must be replaced if:

1. The light on the front plate does not flash green every 40 seconds.
2. The unit is over 10 years old (see “REPLACE BY” label on the side of the unit).
3. If during checking and testing, it fails to operate.
4. If the light on the front plate is flashing amber every 9 seconds (indicating the long life battery is depleted).

7. GETTING YOUR Ei408 SERVICED

If your Ei408 fails to work after you have read this leaflet, contact Customer Assistance at the nearest address given at the end of this leaflet. If it needs to be returned for repair or replacement put it in a padded box with the battery disconnected. Slide switch to “off” position (see Figure 2). Send it to “Customer Assistance and Information” at the nearest address given on the Ei408 or in this leaflet. State the nature of the fault, where the unit was purchased and the date of purchase.

Note: It may be necessary, sometimes, to return additional units (see individual instruction leaflets) along with the Ei408, if you cannot establish which is faulty.

8. FIVE YEAR GUARANTEE (Limited)

Ei Electronics guarantees this product against any defects that are due to faulty material or workmanship for a five year period after the original date of purchase. This guarantee only applies to normal conditions of use and service, and does not include damage resulting from accident, neglect, misuse unauthorised dismantling or contamination howsoever caused. Excessive operation of the unit will shorten the battery life and is not covered. If this product has become defective it must be returned to the nearest address listed in this leaflet (see “Getting Your Ei408 Serviced”) with proof of purchase. If the product has become defective during the five year guarantee period we will repair or replace the unit without charge. This guarantee excludes incidental and consequential damages.

Do not interfere with the product or attempt to tamper with it. This will invalidate the guarantee.

The crossed out wheelie bin symbol that is on your product indicates that this product should not be disposed of via the normal household waste stream. Proper disposal will prevent possible harm to the environment or to human health. When disposing of this product please separate it from other waste streams to ensure that it can be recycled in an environmentally sound manner. For more details on collection and proper disposal, please contact your local government office or the retailer where you purchased this product.



Hereby, Ei Electronics declares that this Ei408 RadioLINK Switched Input Module is in compliance with the essential requirements and other relevant provisions of Directive 2014/53/EU. The Declaration of Conformity may be consulted at www.eielectronics.com/compliance



Hereby, Ei Electronics declares that this Ei408 RadioLINK Switched Input Module is in compliance with the essential requirements of the Radio Equipment Regulations 2017. The Declaration of Conformity may be consulted at www.eielectronics.com/compliance

Aico
Oswestry, Shropshire SY10 8NR, U.K.
Tel: 01691 664100
www.aico.co.uk

Ei Electronics
Shannon, V14 H020, Co. Clare, Ireland.
Tel: +353 (0)61 471277
www.eielectronics.com