

LED Panel Backlit 600

Installation Instructions



 **Please read these instructions carefully before installation**
Leave a copy for the user/maintenance engineer for future reference

Important Safety Information

- It is recommended that this fitting is installed, inspected and maintained by a qualified Electrician.
- Installation should be carried out in accordance with the latest edition of the IET Wiring Regulations (BS 7671) and the latest Building Regulations. If in doubt, consult a qualified electrician.
- These products are designed for connection to a 220-240V~50/60Hz mains supply.
- Before commencing any installation or maintenance work, ensure that the electricity supply is disconnected / isolated.
- Ensure that all electrical connections are tight with no loose strands including factory made connections.
- Please note the IP rating of this luminaire when deciding the location for installation.
- This product is supplied with a non-dimmable driver as standard.
- Suitable to fit 15mm and 25mm exposed T bar ceiling grids.
- This luminaire is suitable for indoor use only.
- Do not cover this product with any insulation matting or other similar material.
- This is a class II construction luminaire, no earth required.
- Suitable for use in ambient room temperatures of -10°C to +40°C.
- MCBs may require to be uprated to allow for increased initial inrush current.
- Do not carry out any insulation resistance tests with the luminaire connected to the circuit.
- The LED light source fitted in this product is non-replaceable, the whole luminaire must be replaced when the LED reaches the end of its life.

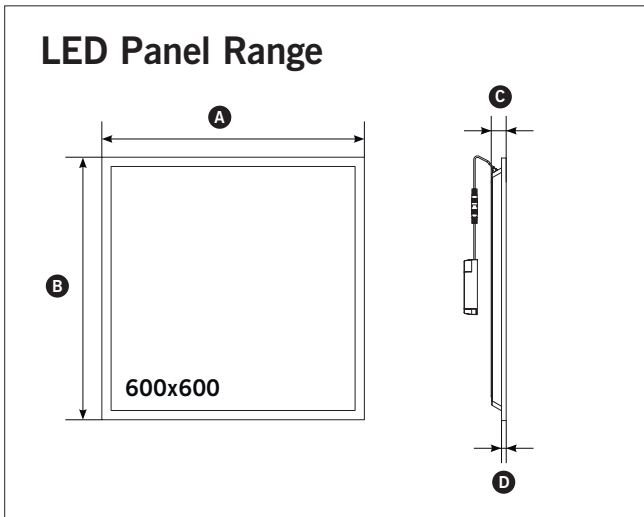

Accessories*

Part No.	Description	Use with Product
LXPANB66SMBK	Surface Mount Box Kit	600x600
LXPANB66SCK	Suspension Cable Kit	600x600
Emergency	Remote 3hr Emergency Pack - Available on request	
Dimmable	1-10V/DALI Dim Driver – Available on request	

* Please refer to the website for further details and installation information.

Technical Specifications

Part No.	Description	TP Fire Rating	Wattage	Measurement				Lumen Output	IP Rating	Power Factor	Ra	Class Rating	Colour Temperature
				A	B	C	D						
LXPANB30LED66NW	LED Recessed Panel Backlit 600	TP(b)	30W	595	595	34	8mm	3000Lm	IP20	> 0.90	> 80	Class II	4000K
LXPANB30LED66CW	LED Recessed Panel Backlit 600	TP(b)	30W	595	595	34	8mm	3000Lm	IP20	> 0.90	> 80	Class II	6000K
LXPANB28LED66NW/A/19	LED Recessed Panel Backlit 600 UGR<19	TP(a)	28W	595	595	34	8mm	3100Lm	IP20	> 0.90	> 80	Class II	4000K
LXPANB28LED66CW/A/19	LED Recessed Panel Backlit 600 UGR<19	TP(a)	28W	595	595	34	8mm	3100Lm	IP20	> 0.90	> 80	Class II	6000K

Important Installation Information

Select a suitable mounting position and check that the site of the installation can support the weight of the product. Do not cover the rear of the panel housing or the driver and ensure that there is always adequate free air ventilation around the product.

Ensure that the mounting area is clean and free from any obstructions. The installation must not infringe on gas/water pipes or any other electrical cables or mechanical services which may be hidden behind the ceiling.

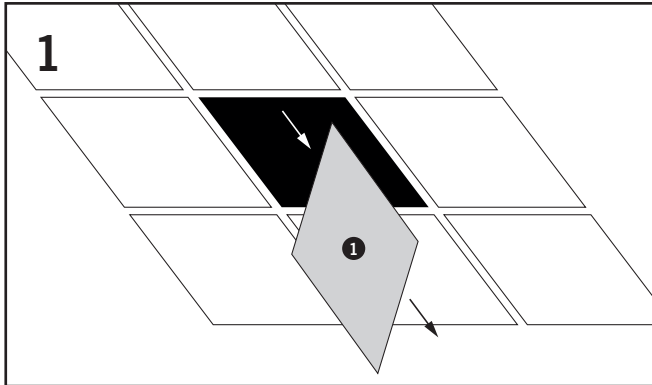

Always switch off / Isolate the mains power supply before installation or servicing. When installing into a suspended ceiling grid, remove the tile or tiles **1** from the position where the LED Panel is to be located.

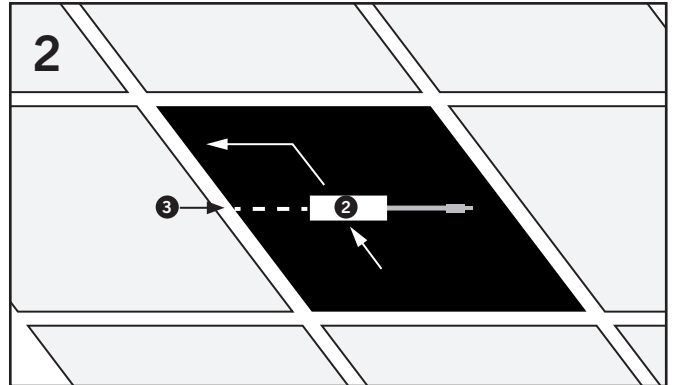

Locate the LED driver **2** into the open ceiling void and connect the mains supply cable **3** to the input terminals of the driver. Ensure that the correct polarity is observed: LIVE (L) Brown to terminal marked L – NEUTRAL (N) Blue to terminal marked N

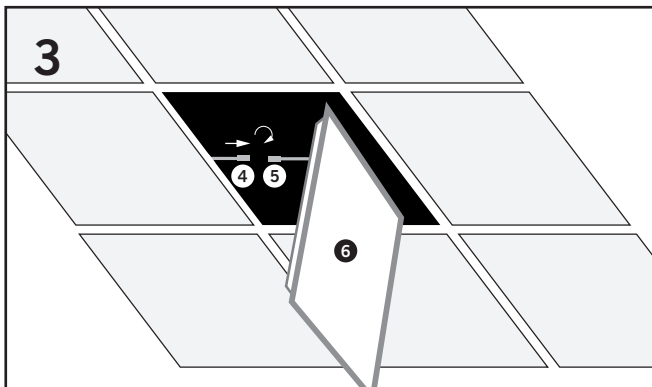

Connect the driver plug lead **4** which is pre-wired into the output terminals of the LED driver to the panel plug lead **5** which is attached to the LED Panel **6**. Rotate the two plugs 90 degrees to ensure a secure connection.

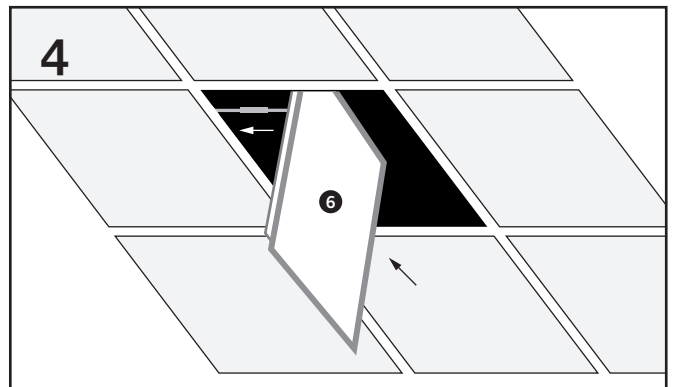

Place the LED Panel **6** into the open ceiling void and locate the panel frame onto the exposed T bar grid. Restore the mains power supply, switch on and test for satisfactory operation.

Important - Do not place the LED driver or the remote emergency pack directly onto the rear of the luminaire.

Warranty

This product is protected by guarantee in the UK for a period of 5 years warranty from the date of purchase against any defects in materials or workmanship. Should this product fail during the warranty period it will be repaired or replaced with the same or equivalent product free of charge, subject to providing the original receipt/invoice or proof of the original date of purchase and return of the faulty unit. If in our sole discretion, we are unable to repair or replace a defective product, we will refund the purchase price of the product. The warranty is invalid if in our judgment the product fails due to incorrect installation not conforming to our product instructions or installation within an improper working environment. The warranty will not apply if the product fails due to damage in storage, shipment, accident or misuse. Modification to the product in any way or removal of the batch number will void the warranty. Luxna Lighting does not accept responsibility for any installation, labour or travel costs which may be associated with the replacement or return of any faulty products. Our maximum liability under the terms of this warranty is limited to the purchase price of the product. Your statutory rights are not affected. Luxna Lighting reserves the right to alter product specifications without prior notification. Terms and conditions are also subject to change without prior notice.