

ACCESSORIES

Technical Specification

Product Code: OVEMCG50

Description: 3 Hour Emergency Conversion Pack For Use With LED Panels

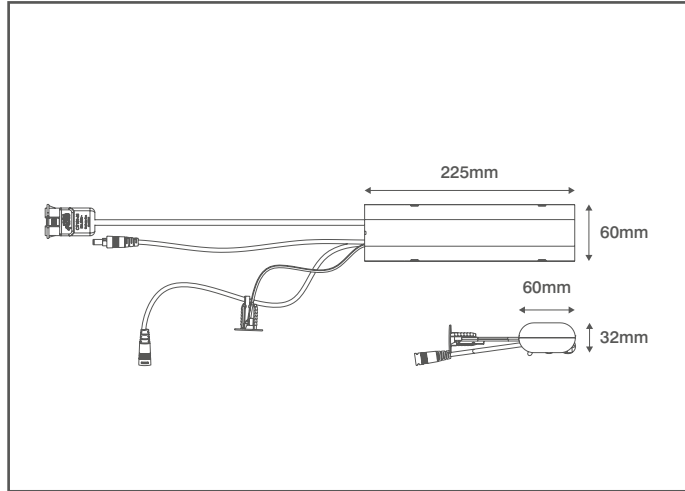
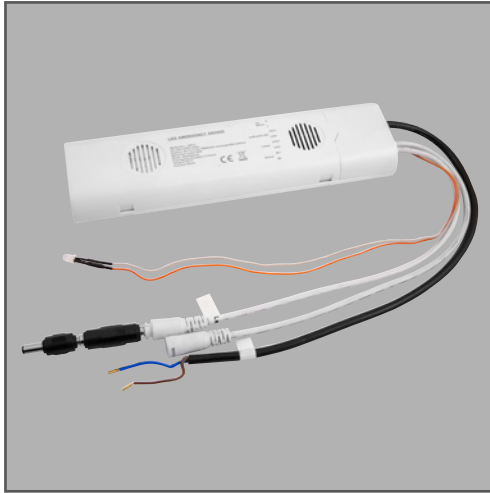

General Information

Dimensions	225mm (L) x 60mm (W) x 32mm (D)
Materials	Housing: Polycarbonate
Product Weight	0.495Kg
Ingress Protection	IP20
Compatible Fittings	Inceptor® Slate, Jura and AluPanel Ranges
Warranty	4 Years

Supply & Power

Input Voltage & Frequency	220-240V~ 50/60Hz
Electrical Safety	Class II (Double Insulated)
Ambient Temperature (Ta)	0°C - +50°C
Critical Temperature	+70°C
Power Consumption	4W
Charge Current	170-280mA
Output Current	640-1000mA
Battery Specification	4.8W 3000mAh Ni-Cd
Battery Cell	4 Cell
Charging Time	24 Hours
Installation Requirements	Can be wired as Maintained or Non-maintained
Emergency Duration	3 Hours Minimum