



## RADIO FREQUENCY FAST FIX MAINS HEAT DETECTOR

WITH 10 YEAR RECHARGEABLE LITHIUM BATTERY

**FAST  
FIX RF**



GUARANTEE



BATTERY



### FEATURES

- Wirelessly interconnect up to 20 detectors
- 10yr Rechargeable Lithium Battery Backup
- Loud 85dB alarm
- Fast Fix base included
- Insect proof
- Test function and hush feature
- Tamper proof

### TECHNICAL INFORMATION

Scheme Rating:	D1
Detection Type:	Heat Sensitive
Power Source:	220-240v
Battery Backup:	Rechargeable Lithium Battery with 10 year life
Alarm Sound Level:	85dB at 3 metres
Operating Temp:	0°C ~ 40°C
Operating Current:	<40mA operation
Radio Frequency Range:	Up to 80m in open areas & 30m indoors
Coverage Area:	60m <sup>2</sup> max at 2.4m mounting height
Weight:	162g
Approvals:	EN14604:2005

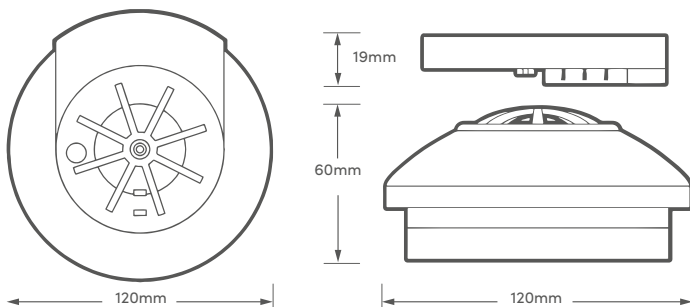

Product Code: HSSA/HE/RF10