

SPA104

Type 2 Surge Arrester

The **SPA104** is for installation at LPZ 0_B -1 or higher, protecting low voltage equipment from surge damage.

Designed according to IEC 61643-11 / GB 18802.1. This device has a pluggable modular SPD Class II (Class C) for TT and TN power supply system.

According to the lightning protection zones concept, this device is for installation at LPZ 0_B -1 or higher. This surge protective device is usually installed in the distribution-box or feeder bus of the UPS, protecting devices or equipment downstream.

A fuse must be installed at the upstream of the SPD / lightning arrester to make sure that the protected system has double protection.



SPA104

Dimensions in mm

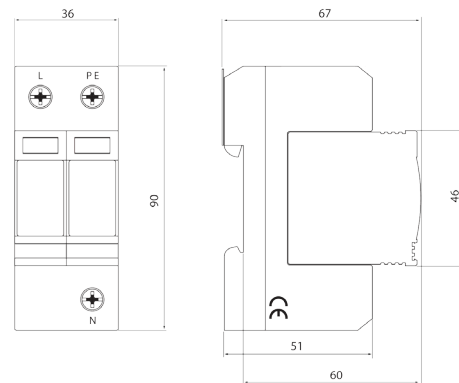

Internal Wiring

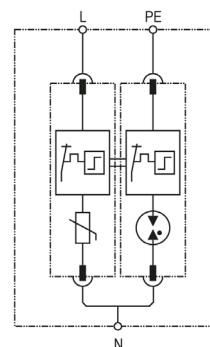

Installation

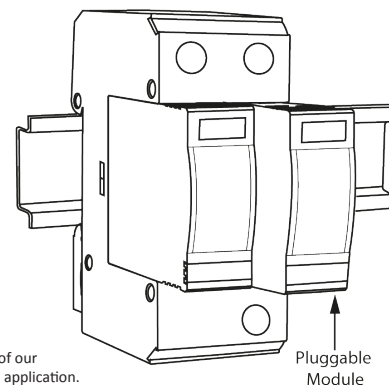
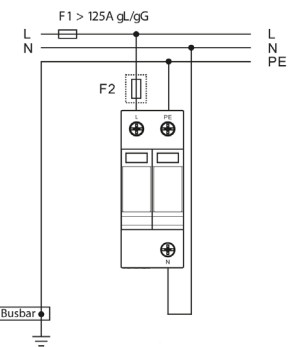

Pluggable Module

Specification	
Test standards: EN 61643-11; IEC 61643-11; GB 18802.1; YD/T 1235.1	TYPE 2 - CLASS II
Rated voltage (max. continuous voltage)	U_c 275V (L-N) 255V (N-PE)
Nominal operating voltage	U_N 230VAC
Nominal discharge current (8/20)	I_n 20kA (L-N) 40kA (N-PE)
Max. discharge current (8/20)	I_{max} 40kA (L-N) 65kA (N-PE)
Voltage protection level at I_n	U_p ≤ 1.3kV (L-N) ≤ 1.8kV (N-PE)
Voltage protection level 5kA	U_p ≤ 1.0kV (L-N)
Max. Temporary overvoltage withstand (TOV)	U_T 335V/5s (L-N) 1200/200ms (N-PE)
Response time	t_A ≤ 25ns (L-N) ≤ 100ns (N-PE)
Follow current extinguishing capability at U_c	I_f 100Arms(N-PE)
Max. back up fuse	125A gL/gG (L-N)
Operating temperature range	ϑ -40°C to +80°C
Cross-sectional area	1.5mm - 25mm solid 35mm flexible
Connection type	Screw Terminal
Mounting on	35mm DIN rail
Enclosure material	Thermoplastic, UL94-V0
Mechanical protection level	IP20
Certification	CE (LVD, EMC)
Type of remote signalling contact	Switching contact
Switching capacity	U_N / I_N AC:250V/0.5A DC:250V/0.1A, 125V/0.2A, 75V/0.5A
Cross-sectional area for remote signalling contact	Max. 1.5mm solid / flexible
Part Code	SPA104

Revision: ANW-v4, 25/06/19
Information subject to change without notice.

All of the above information, including drawings, illustrations and graphic designs, reflects our present understanding and is to the best of our knowledge and belief correct and reliable. Users, however, should independently evaluate the suitability of each product for the desired application.