

VIRGO DUAL-POWER DOWNLIGHT

VIRGO-12/18-120/200TC

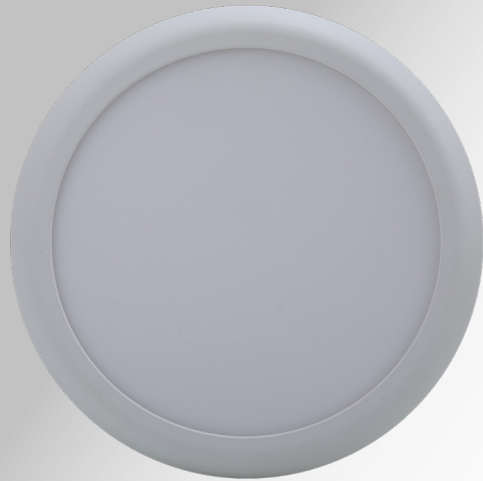

LIGHTING & SECURITY



SWITCHABLE
FROM BACK

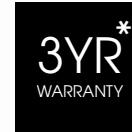
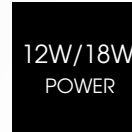

Q-DRIVE

EPISTAR

Driver as Standard

LED's inside

Specification	Virgo Downlight
System Power	18W/25W
Driver Manufacturer	Q-Drive
LED Chipset	Epistar
Diffuser	Opal
LED Efficacy	70Lm/cW (WW) 75Lm/cW (NW/CW)
Lumen Output	18W: 840Lm (WW)/900Lm (NW/CW) 25W: 1260Lm (WW)/1350Lm (NW/CW)
Power Factor	0.9
IP Rating	IP44
Beam Spread	110°
Colour Type	Tri-Colour
Colour Temperature	3000K/4000K/6000K
Housing Material	Polycarbonate
Cut Out	120 - 200mm
Operating Temperature	-20 to 40 °C
Input Voltage	AC 220-240V
Weight	0.53kg
Dimensions	220mm x 21.5mm
Lifetime	50,000 hours, L70-B10 (Ta 25 °C)
CE Standards	EN60598-1, EN 60598 2-2, EN62493, EN55015, EN61547, EN61000-3-2, EN61000-3-3, EN62722-1, EN62722-2-1 and EN50581
CE Directives	LVD, EMC, ERP & RoHS

* Warranty terms and conditions apply

TECHNICAL DRAWINGS

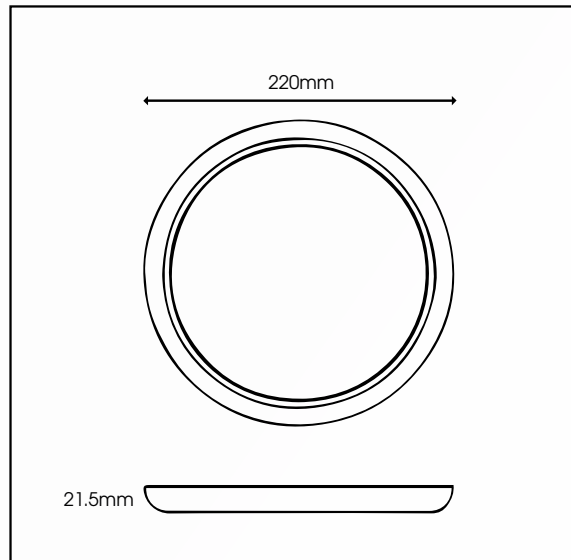

MODULAR & RECESSED RANGE