

LXERP/55/EM3

3Hr Emergency Remote Pack



Please read these instructions carefully before installation
Leave a copy for the user/maintenance engineer for future reference

Important Safety Information

- Before commencing any installation or maintenance work, ensure that the electricity supply is disconnected / isolated.
- It is recommended that this product is installed, inspected and maintained by a qualified Electrician.
- Installation should be carried out in accordance with the latest edition of the IET Wiring Regulations (BS 7671) and the latest local Building Regulations. If in doubt, consult a qualified electrician.
- This product is designed for connection to a 220-240V ~ 50/60Hz mains supply.
- Ensure that all electrical connections are tight with no loose strands including factory made connections.
- Note the IP rating of this product when deciding the location for installation.
- This product is suitable for indoor use only.
- This is a class II construction product.
- Suitable for use in ambient room temperatures of 0°C to +45°C.
- Do not carry out insulation resistance tests with the product connected to the circuit.
- This unit has Deep discharge circuit protection, Short circuit protection and Polarity reversal protection for the battery.
- For use with LED modules only.
- Contains replaceable battery: LiFePO4 3.2V 3.6Ah

Technical Specifications

Rated supply voltage	220-240VAC
Mains frequency	50/60Hz
Dimensions (LxWxH)	188.5 x 60 x 33mm
Mains input current	25mA
Battery charge current	200mA
Charging time	24 Hours
EM LED Output voltage range	10-55VDC
SELV for output voltage	<60VDC
EM LED current	33-220mA
EM LED power (Typical)	2.5W
Response time	0.5sec
Emergency duration	3 Hours
Polycarbonate housing	850°C glow wire
Ambient temperature ta	0°C ~ +45°C
Max. case temperature tc	+70°C
Protection class	Class II
IP Rating	IP20
Battery type	LiFePO4 3.2V 3.6Ah

Dimensions

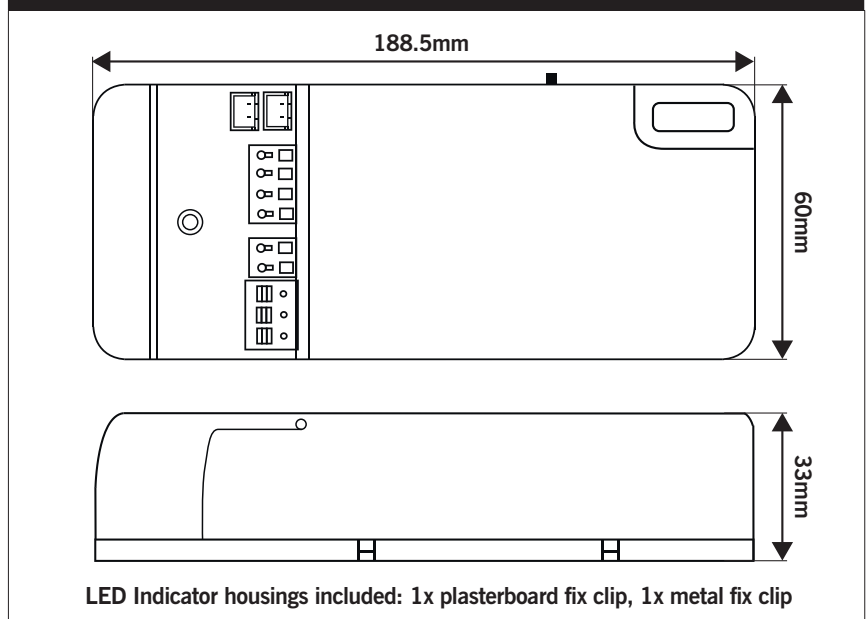

Important Installation Information

Isolate the mains power supply before commencing installation.

Do not cover the product with insulation material and ensure that there is always adequate free air ventilation around the Emergency pack and driver.

Refer to the product wiring diagram on page 2 of this manual for mains supply, Control Gear/Driver and LED Load connections.

Once wiring is complete, the remote pack and connecting cables should be sited so that they are protected from unauthorised disconnection.

Recessed mount clips can be found inside the packaging carton to assist installation of the LED indicator which should be mounted in a suitable location so that it is visible during normal operation.

Once installed and the mains power supply is restored, switch on and test for satisfactory operation. The LED indicator will be illuminated and the supply should be left uninterrupted for a minimum of 24 hours to charge the batteries before attempting the commissioning test.

Wiring Diagram

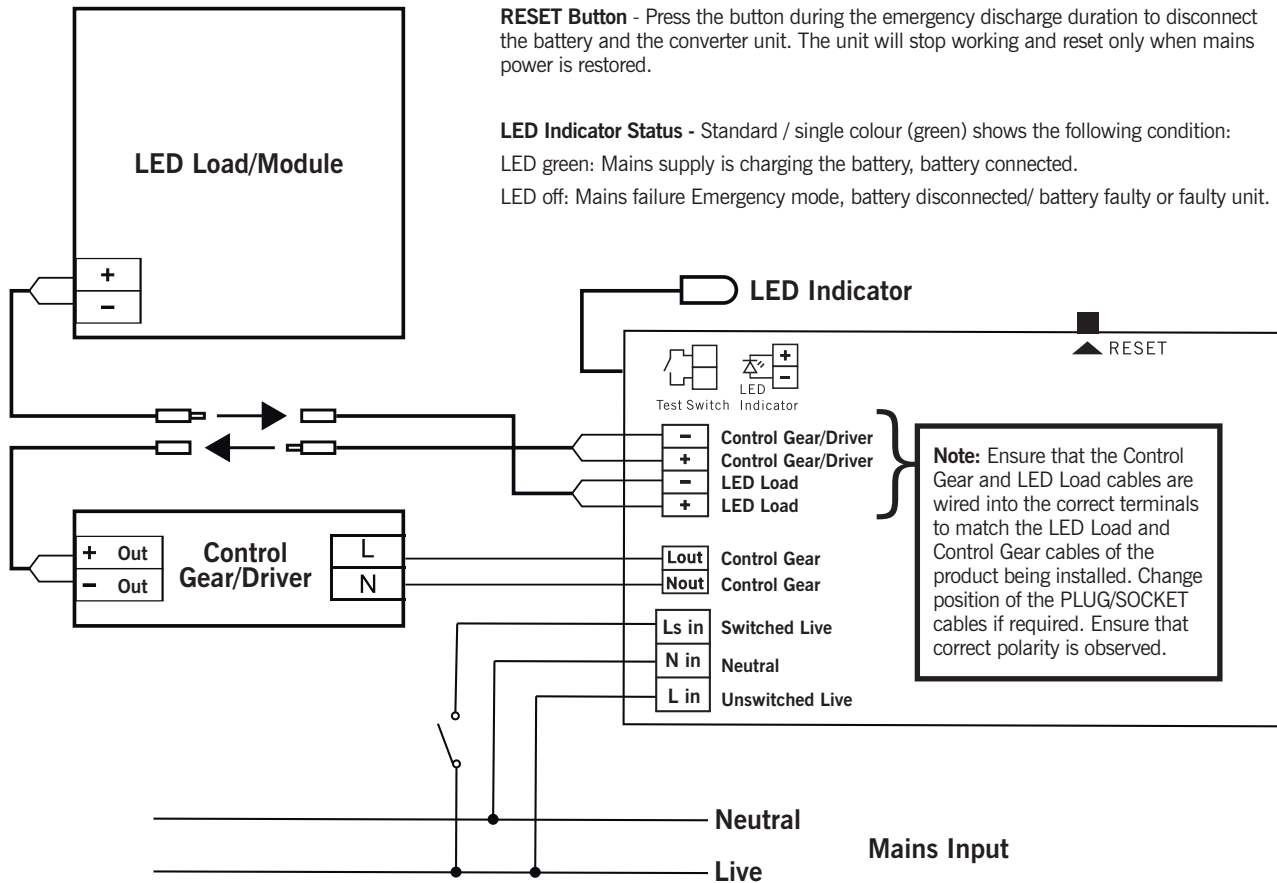

Emergency Pack Converter Connection and Testing

1. The Emergency pack requires an unswitched live supply L in addition to the switched live supply Ls.
2. Ensure that the battery cells supply cable is connected to the Emergency module before mains power is restored.
3. Once installed, the batteries must be charged for a minimum of 24 hours before carrying out a full discharge and commissioning test to check that they are charging correctly and that the maintained 3-hour discharge duration is being achieved. The date should be noted on the battery.
4. The Green LED Indicates that the batteries are charging.
5. Emergency luminaires should be routinely inspected and tested in accordance with current **BS 5266** guidelines. Refer to **BS 5266 & BS EN 50172** for full Emergency Lighting requirements and testing procedures
6. A log report must be completed and kept for the periodic test procedure. A copy of the Emergency test record sheet is included with this product. Further copies can be requested at sales@luxna.co.uk
7. A completed copy of the Emergency test record sheet must accompany any product returned to the manufacturer.

Batteries (*5 year warranty excludes batteries)

The battery cells inside an emergency product are a consumable replaceable item. The batteries have a normal operating designed service life of 4 years and must be replaced in a timely manner to ensure that the integrity of the emergency lighting system is maintained. The battery cells actual service life can be shortened by several variable factors including (but not limited to): Type of installation environment, Room temperature, Number of charge/discharge cycles, power supply interruptions etc. The product should be tested and maintained regularly according to the details within the instruction manual. Should the battery cells fail to provide the minimum rated discharge duration of 3 hours at any time during the products service life, they must be replaced.

This product must not be installed in areas where the ambient area temperature is above or below the recommended operating temperature range 0°C to +45°C

Warranty: This product is protected by guarantee in the UK for a period of 5 years* warranty from the date of purchase against any defects in materials or workmanship. Should this product fail during the warranty period it will be repaired or replaced with the same or equivalent product free of charge, subject to providing the original receipt/invoice or proof of the original date of purchase and return of the faulty unit. If in our sole discretion, we are unable to repair or replace a defective product, we will refund the purchase price of the product. The warranty is invalid if in our judgment the product fails due to incorrect installation not conforming to our product instructions or installation within an improper working environment. The warranty will not apply if the product fails due to damage in storage, shipment, accident or misuse. Modification to the product in any way or removal of the batch number will void the warranty. Luxna Lighting does not accept responsibility for any installation, labour or travel costs which may be associated with the replacement or return of any faulty products. Our maximum liability under the terms of this warranty is limited to the purchase price of the product. Your statutory rights are not affected. Luxna Lighting reserves the right to alter product specifications without prior notification. Terms and conditions are also subject to change without prior notice.