

ICARUS PIR 2LT WALL

81011

Fitting/replacing bulbs: Max. 5W LED GU10

- This fitting has been designed to use energy efficient LED bulbs. Ensure that the minimum distance to the illuminated surface is not less than 0.5m (50cm).
- When changing a bulb, always switch off at the mains and allow the bulb to cool before handling. Dispose of used bulbs carefully. Do not exceed the wattage stated or use a different shape bulb from that indicated on the fitting. Use of the incorrect bulb will damage the product and invalidate the guarantee.



PIR Adjustment

To access the adjustment screws flip down the black cover over the PIR sensor. Take great care when adjusting the sensor screws not to over tighten as they can be easily broken.

- The unit must be installed in a vertical position, and fitted 1.8-2.5m above the ground.

- The PIR sensor can be adjusted, allowing the detection distance to be altered to suit the location. The detection angle is set at 110°. The duration that lamp stays on can also be altered from 5 seconds - 5 minutes. The LUX rang is 10-2000 lux. Use a small screwdriver to adjust the "TIME" and "SENS" screws. When adjusting the sensitivity (detection distance) in daylight it will be necessary to cover the sensor to simulate night time.

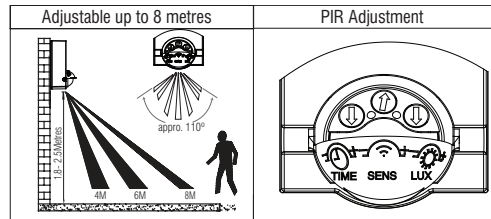

The PIR sensor has a **manual override function** which can be operated by taking the following steps:

- When first switched on, the PIR sensor “warms up” for approx 1 minute and then goes into AUTO mode.
- In AUTO mode, switch the power OFF and ON twice within 3 seconds, the PIR sensor will switch to MANUAL mode. In MANUAL mode, the light will remain ON permanently, without the PIR function.
- To return to AUTO mode, switch the power OFF and ON twice within 3 seconds.
- In either mode, if the power is switched OFF more than 6 seconds, the PIR sensor will go through 'warm up' process again when you turn it on next time.

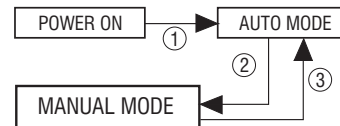

Technical data

Supply Voltage: 240 V~, 50 Hz
 Bulb Type: 2 x Max. 5W LED GU10



Conformity with all relevant EC Directive requirements.



The power supply is double insulated and does not require connection to an Earth circuit.



Waste electrical products should not be disposed of with household waste. Please recycle where facilities exist. Check with your Local Authority or local store for recycling advice.



This product is rated at IP44.



This product is rated at IK05.

Care and Safety

We recommend cleaning with a soft dry cloth. Do not use solvents or abrasive cleaners as these could damage the finish. For your safety, always switch off the power supply before changing lightbulbs, or cleaning.



Thank you for purchasing this light fitting. Please read the instructions carefully before use to ensure safe and satisfactory operation of this product. Please retain these instructions for future reference.

Warning

 This light fitting is double insulated and does not require connection to an Earth circuit.

Please read these instructions carefully before commencing any work.

This unit must be fitted by a competent and qualified electrician.

Install in accordance with the IEE Wiring regulations and current Building Regulations.

Check the pack and make sure you have all the parts listed.

To prevent electrocution switch off at the mains supply before installing or maintaining this fitting.

Ensure other persons cannot restore the electrical supply without your knowledge.

If you are in any doubt, please consult a qualified electrician.

If replacing an existing fitting, make a careful note of the connections.

This light should be connected to a circuit with a 30mA RCD fitted.

This product is suitable for location in or near a marine environment.

The entire unit gets hot whilst on for a period of time, ensure the fitting is mounted out of arms reach.

Waste electrical products should not be disposed of with household waste. Please recycle where facilities exist. Check with your local authority or retailer for recycling advice.

Layout

Plan the desired layout of these fittings carefully, ensuring the cables will reach the distances between the junction box and the each light fitting.

Avoid locating any cables in positions that would cause a hazard. Position cables and outdoor rated junction boxes (not supplied) away from areas where they may be at risk from being cut, trapped or damaged.

We recommend that you use H05RN-F specification cable (not supplied) which is an outdoor grade, rubber sheathed cable.

The mains supply cable must have a minimum cross section area of 1.0mm².

Cables must be protected using suitable conduit or plastic trunking.

Installation

Existing fittings must be completely removed before installation of a new product. Before removing the existing fitting, carefully note the position of each set of wires.

Note that the switch is turned off before installation.

Ensure that the screws and cable entry points are sealed to maintain the IP rating of the product.

After deciding the layout of the light fittings ensure that the cables are long enough to connect to desired positions.

- Determine the position of your light fitting taking into account the entry position of the cable and the **ARROW** indicating which **WAY UP** the base is to be fitted. Make sure there is sufficient cable coming out of the wall to connect to the terminal block. Ensure that the mounting surface is solid, preferably a brick or block wall and ensure that there are no other cables or pipes beneath the surface.
- **Diagram A.** Fit the 2 threaded posts in the back plate and bring the mains cable through the rubber grommet then use the back plate as a template and mark the 2 fixings holes, making sure the back plate is correctly aligned so that the threaded bolts are horizontal. Use appropriate fixings to secure the back plate to the wall. Ensuring the **drain hole** is at the base of the mounting box.

- **Diagram B.** Connect the house wiring to the internal terminal block. The cable entry grommet must be securely in place to ensure that the water ingress protection is maintained. **NOTE: This is a Class II fitting and must not be earthed.** If you have any earth cables make sure that they are connected to each other – to maintain earth continuity throughout your property – and wrap the earth terminal and connections in 2 layers of good quality insulation tape and keep them away from the terminal connections of the fitting. Connect the incoming mains as per the diagram.

Diagram A.

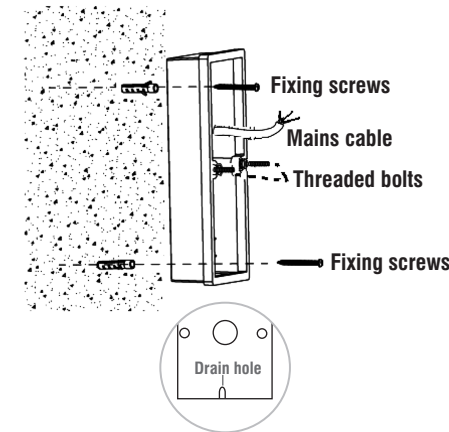
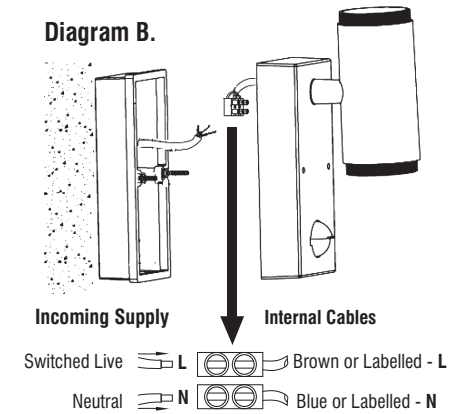
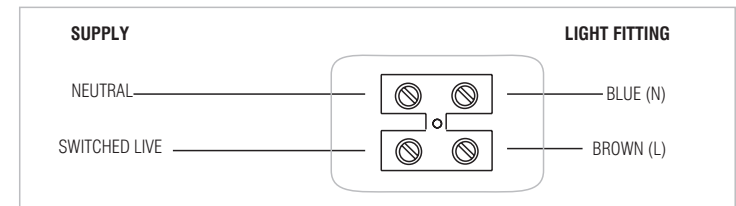

Diagram B.



Wiring

Having correctly identified the wiring from your light fitting, connect to the approved outdoor rated external terminal block in the following way:



Check that...

You have correctly identified the wires
The connections are tight

No loose strands have been left out of the connection block
Reseal the approved outdoor rated external terminal block

Commissioning

- **Diagram C.** Fit the terminal block onto the post in the back plate and then fit the front frame over the 2 threaded bolts in the back plate and secure with the 2 threaded nuts. Take care not to trap or strain the internal cables.
- Fit the appropriate bulbs into the lamp holders **NOTE: Never fit bulbs of a higher wattage than specified on the label (as this may cause overheating and damage the fitting).**
- Replace the bulb covers (1).
- Replace fuse or circuit breaker and switch on. Your light is now ready for use.

Diagram C.

