

SIGHT PLUS

91146



Battery Replacement

If after routine operation check, the lamp does not remain lit for the three hour period, a new battery pack may be required.

- Switch off the electricity at the mains, both switched and permanent supply.
- Allow batteries to fully discharge then reconnect to supply and allow to charge for 24 hours.
- Test again for 3 hours, if light does not remain lit change the battery pack as follows:
 - Disconnect from the mains supply both permanent and switched supply.
 - Undo two screws at the end of the product then pushing the tow quick release tabs on the one side of the front cover to separate the front cover, diffuser, from product. Keep screw in safe place for refitting later.
 - Undo the two screws holding the gear tray and fold down.
 - Unplug the battery lead from the lead coming from the PCB. Remove any cable ties around the cables.
 - Remove the battery pack and lift the battery pack out of the fitting. Waste electrical products should not be disposed of with household waste. Please recycle where facilities exist. Check with your local authority or retailer for recycling advice.
 - **Replace the battery with a 3.6V 800mAh Ni-Cd only.** Use of a different type of battery will damage the product.
 - Write current date on the new battery pack.
 - Fit new battery pack in position and re-secure using the screws set aside earlier. Refit the cable ties in position and then plug battery pack into the PCB.
 - Plug battery pack into circuit board.
 - Close and secure gear tray.
 - Replace diffuser.
 - Restore power and allow to charge for 24 hours.
 - Perform full operation check and update test record.

Technical data

Supply Voltage:	240 V~, 50 Hz	Duration: 3 hours (180 minutes)	Change over Time: Approximately 1s
Bulb Type:	4.5W LED (SMD), 6500K	Operating Temperature: -20°C to 45°C	Battery Specification: 3.6V 800mAh Ni-Cad
		Maximum Operatin Humidity: 10-90%	Battery Charge Time: 24 hours
			Battery warranty: 2 years

The light source of this luminaire is not replaceable; when the light source reaches its end of life the whole luminaire shall be replaced.



Conformity with all relevant EC Directive requirements.



The power supply is Double Insulated and does not require connection to an Earth circuit.



Waste electrical products should not be disposed of with household waste. Please recycle where facilities exist. Check with your Local Authority or local store for recycling advice.



This product is rated at IP65.

Care and Safety

Live Voltages may be present in this unit even when turned of or when completely disconnected.

We recommend cleaning with a soft dry cloth. Do not use solvents or abrasive cleaners as these could damage the finish.

For your safety, always switch off the power supply before cleaning.

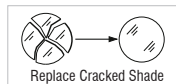

This bulb is protected by a shade. This part must be replaced immediately should the shade become cracked or damaged. This fitting must not be used without the shade in place.

Thank you for purchasing this light fitting. Please read the instructions carefully before use to ensure safe and satisfactory operation of this product. Please retain these instructions for future reference.

Warning

 This light fitting is double insulated and does not require connection to an Earth circuit.

Please read these instructions carefully before commencing any work

This unit must be fitted by a competent and qualified electrician.

Install in accordance with the IEE Wiring regulations and current Building Regulations.

Check the pack and make sure you have all the parts listed.

To prevent electrocution switch off at the mains supply before installing or maintaining this fitting. Ensure other persons cannot restore the electrical supply without your knowledge.

This light fitting should be connected to a fused circuit.

If replacing an existing fitting, make a careful note of the connections.

These products should not be fitted to PIR circuits or short duration timed switches.

This product is not suitable for dimming.

Waste electrical products should not be disposed of with household waste. Please recycle where facilities exist. Check with your local authority or retailer for recycling advice.

Layout

Plan the desired layout of these fittings carefully, ensuring the cables will reach the distances between each light fitting.

Avoid locating any cables in positions that would cause a hazard. Position cables away from areas where they may be at risk from being cut, trapped or damaged

The mains supply cable must have a minimum cross section area of 1.0mm².

This product is designed to be fitted into a suspended ceiling or wall mounted.

This product has special protection against the ingress of moisture and is IP65 rated.

Installation

Existing fittings must be completely removed before installation of a new product. Before removing the existing fitting, carefully note the position of each set of wires.

Note that the switch is turned off before installation.

After deciding the layout of the light fittings ensure that the cables are long enough to connect to desired positions.

- Undo two screws at the end of the product then pushing the tow quick release tabs on the one side of the front cover to separate the rear casing from product. Keep screw in safe place for refitting later.
- Choose the cable entry holes on the rear casing and drill out the conduit knockouts accordingly.
- This unit can be mounted on the wall or ceiling. After deciding the mounted way accordingly, Using the rear casing as a template mark the position to drill out the fixing holes. Take care to avoid damaging any concealed wiring and pipes. The correct fixings should be used, depending upon the surface to be mounted.
- Fix the rear casing into the position with the installation plugs and screws (supplied).
- Pull the cable through the cable entry hole and seal to maintain the IP rating, and wire as detailed Wiring Diagram.
- Re-clip the front panel in place and re-secure the diffuser using the screws. Ensure that the seal is correctly fitted.
- Replace fuse or circuit breaker and switch on. Your light is now ready for use.

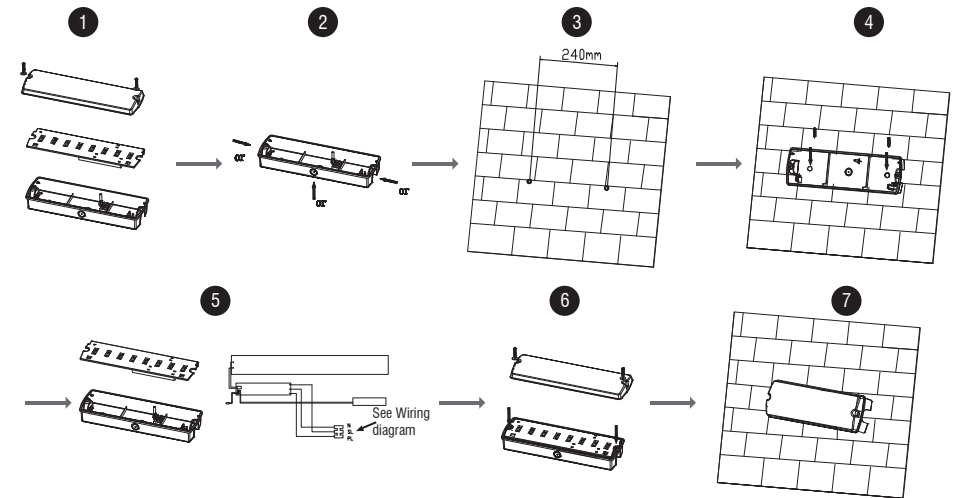

Wiring

This product is double insulated and must not be earthed. If there are any incoming earth cables, they must be joined together and well insulated with good quality insulation tape. This is to ensure earth continuity throughout your property.

Having correctly identified the wiring from your existing light fitting, pull the mains wire through the hole and connect to the quick fit connection block in the following way, using the supplied link cables where necessary:

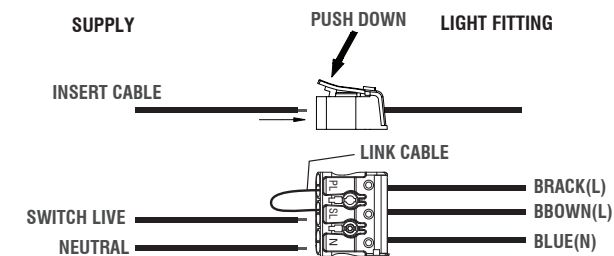

Check that...

- You have to correctly identified the wires.
- The connections are tight.
- No loose strands have been left out of the connection block.