

SCORCH DIMMABLE FIXED

SFR-10-TC

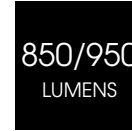

LIGHTING & SECURITY

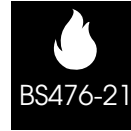
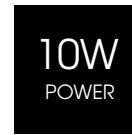

Q-DRIVE

Driver as Standard

EPISTAR

LED's inside

TECHNICAL DRAWINGS

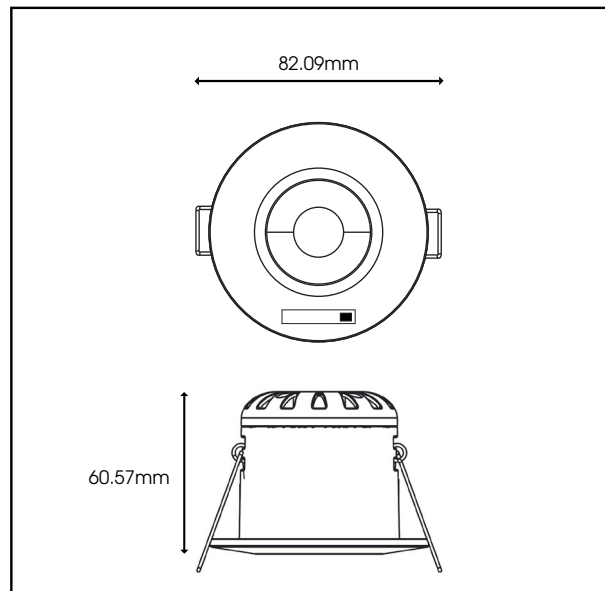

Specification	Scorch Fire Rated Downlight
System Power	10W
Driver Manufacturer	Q-Drive
LED Chipset	Epistar
Colour Rendering Index	>80
Lumen Output (Variable)	850Lm (Warm White), 950Lm (Neutral White), 850Lm (Cool White)
LED Efficacy (Variable)	85 Lm/cW (Warm White), 95 Lm/cW (Neutral White), 85 Lm/cW (Cool White)
Dimmable	Trailing Edge (20 fittings max)
Power Factor	>0.9
IP Rating	IP65
Beam Spread	40 °
Colour Temperature	3000K/4000K/6000K
Housing Material	Aluminium Heat Sync & Steel Fascia
Ambient Temperature	50 to 75 °C
Input Voltage	230VAC, 50-60Hz
Fire Rating	BS476-21
Lamp Type	COB
Building Regs	Part L
Cut Out	67mm
Weight	0.34kg
Dimensions	ø82.09mm x 60.57mm
Lifetime	50,000 hours, L70-B10 (Ta 25 °C)
CE Standards	EN60598-1, EN 60598 2-2, EN62493, EN55015, EN61547, EN61000-3-2, EN61000-3-3, EN62722-1, EN62722-2-1 and EN50581
CE Directives	LVD, EMC, ERP & RoHS

* Warranty terms and conditions apply

LUMINOUS INTENSITY DISTRIBUTION DIAGRAM

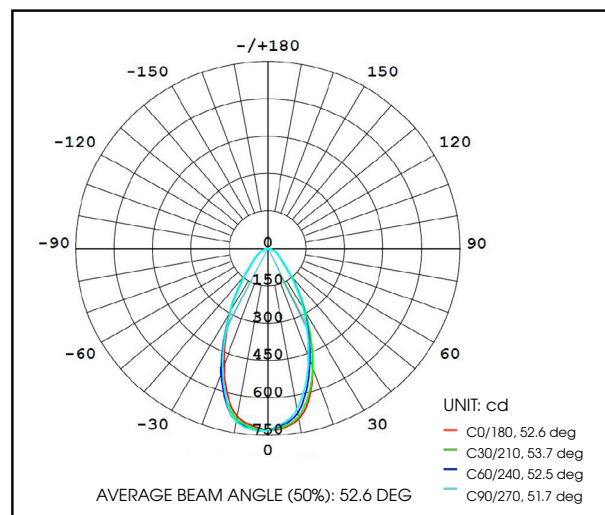

MODULAR & RECESSED RANGE