



LIGHTING • FIRE & CO DETECTION



BATTERY OPERATED CARBON MONOXIDE DETECTOR

WITH DIGITAL LCD DISPLAY



FEATURES

- 9V Battery powered
- Self test on sensor & self diagnostic
- User replaceable battery
- Digital display
- Reset feature
- Low battery warning
- Power/alarm indicator

TECHNICAL INFORMATION

Detection Type:	Electrochemical
Power Source:	9v Battery
Alarm Sound Level:	85dB at 3 meters
Operating Temp:	-10°C - 40°C
Carbon Monoxide Level (time to alarm):	50ppm (60-90 mins) 100ppm (10-40 mins) 300ppm (<3 mins)
Ambient Humidity:	15% to 90% relative humidity
Approvals:	EN50291-1:2010

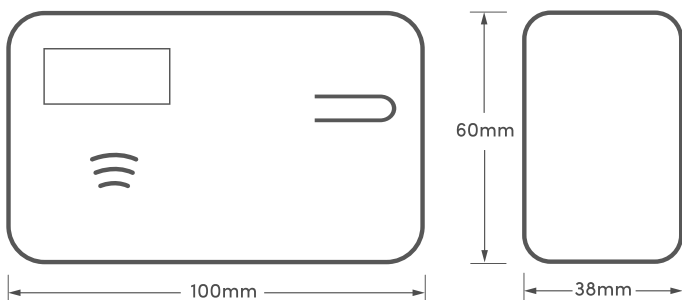

Product Code: HSA/BC-LCD



hispec.co.uk

