

Installing Electric Strike

Technical Information:

Power consumption and current draw

12v DC - 280mA

24v DC - 140mA

Wiring Instruction:

1. Voltage :



2. Sensor (Optional)

<u>Lock Sensor :</u>	<u>Door Sensor :</u>
Purple Com	Orange Com
Brown NC	White NC
Yellow NO	Grey NO

Sensor contact rating: 1A Max, 30V AC/DC

**MOV provided with the package, to be used for surge protection between + and - Power terminals.

The strike can be used in either fail safe or fail secure mode. Ensure that the screw is positioned in either hole as per illustration, and either function can be achieved.

Changing from Fail-Secure to Fail Safe Mode:

Default setting is for fail-secure mode.

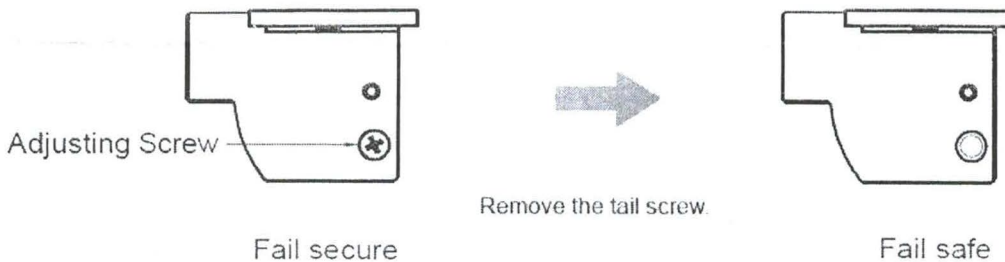

General Installation Instructions:

1. Check with a suitable meter if the regulated power supply or controller being used to operate the strike can provide the required voltage within a +/- 10% tolerance, and that the voltage can be stable during operation under all circumstances.

Warning: Damages caused by connection of an incorrect voltage are not covered by the product warranty.

2. Make a mounting hole on the door frame using the body of the strike as the template to make a proper cutout. Ensure that if the mortise lock being used has a deadlocking snib or trigger, the location of the strike must not allow the snib to enter the 'keep' area.
3. Position the strike and drill the two fixing holes.
4. Ensure that all wiring is correctly terminated and not snagged within the mortise. Install the strike temporarily in this correct position and check that there is no mechanical interference between the door, the lock faceplate and the strike face and extension lip (if fitted) during the closing cycle.
5. Check that no side load pressure is exerted on the strike when the door is closed.
6. Secure the strike and re-check operation.

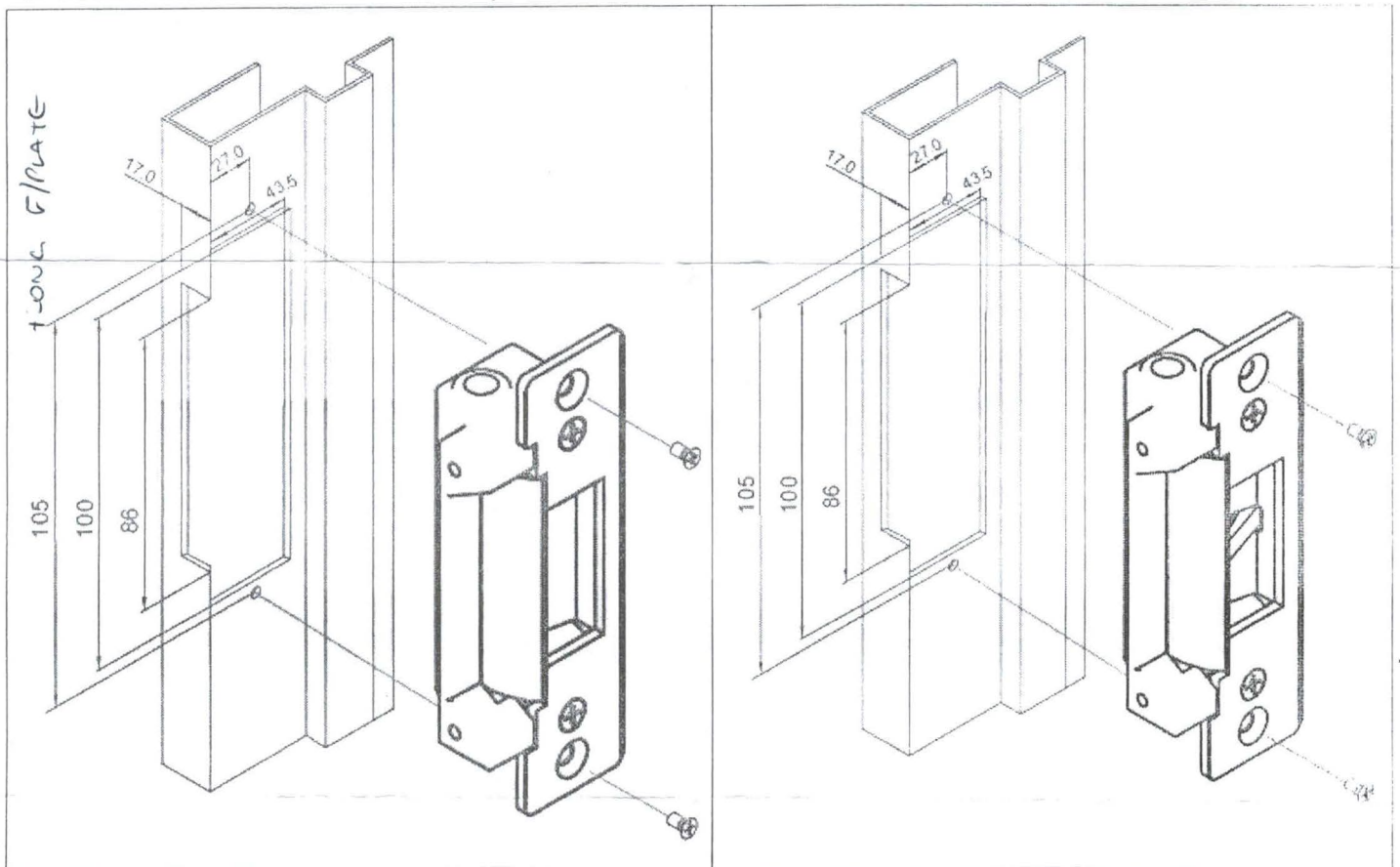

Warranty:

This product is guaranteed for a period of 1 year against defects in manufacture, workmanship or materials provided that all electrical and mechanical installation requirements are adhered to as per this instruction. All third party and consequential claims are expressly excluded from this warranty.

Note: Template dimension not to scale. Technical details and contents are subject to change without notice.