

LXERP/80/ST/EM3

**Universal remote Emergency Pack
- For use with LED Modules only**

Installation & Operating Instructions

Mains voltage:	230VAC ± 10%
Mains frequency:	50 - 60Hz
Power Consumption (Excluding external Driver):	4VA
Emergency output voltage range:	(See product label)
Emergency Duration:	(See product label)
Battery:	(See product label)
Maximum LED current in maintained mode:	2A
Allowed ambient temp:	+5°C to +35°C
Weight:	0.4kg
Charging time:	24 hours
Protection class:	2
Degree of protection:	IP20
Em module complies with:	IEC 61347-2-7
Suitable for installation to EN50172 and BS7671	

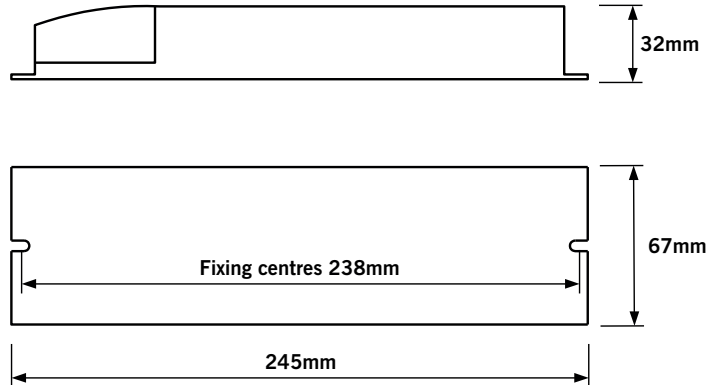

The unit provides reinforced insulation between the mains supply and battery charging circuit and employs self-resetting protection against short-circuit of battery terminals. Normal charging will resume automatically once a fault is removed.

Batteries and Disposal

The battery has a designed service life of 4 years and must be replaced in a timely manner to ensure the integrity of the emergency lighting system is maintained. In any case, the battery should be replaced when it no longer provides the rated duration (3 hours). The manufacturer of the emergency pack is committed to fulfil its obligations as a producer of batteries used in emergency lighting applications. End-of-life batteries may either be returned to the emergency pack manufacturer at the customers cost and arrangements will be made to ensure their correct disposal. Alternatively it may be more convenient for the customer to deliver end-of-life batteries to site(s) of authorized treatment facilities at their cost and it will be ensured that they are accepted back and subsequently treated to the standard required by the regulations.

Installation

NOTE – To comply with regulations, installation must be carried out by a suitably qualified competent person and in accordance with the current IET wiring regulations (BS7671) and building regulations.

Ensure the mains supply is isolated before attempting installation!

The emergency pack is for use with LED Modules only. Please refer to the diagram on page 2 of this leaflet for wiring details of mains supply, LED driver, battery and lamp connections.

If non-locking external plug and socket connectors are used, i.e. without means to prevent accidental disconnection, the remote box should be sited so that it is protected from unauthorised disconnection.

A recessed plastic bezel can be found inside the packaging carton to assist installation of the indicator LED. A 14-16mm hole should be drilled in the required location so it is visible during normal use.

Before use, the battery will need to be connected by plugging in the red and black lead into the appropriate socket, (See diagram on page 2).

To avoid subjecting the battery to excessive charge/ discharge cycles during installation stages, it is strongly recommended the battery is only connected when the mains supply is stable and the product is ready for commissioning.

Once all the necessary connections have been made, affix cable clamps to secure cables in place, place the plastic end cover on and fix with screws provided to prevent unauthorised access.

Commissioning:

Once the luminaire has been installed and availability of the unswitched supply is deemed stable, **connect the battery, then apply mains power to begin the commissioning process.**

After applying power, the module will enter commissioning mode where it will carry out an initial 24 hour charge and a then a full Duration Test. Once this commissioning test is complete, a further 24 hours will be needed to recharge the battery before normal use.

After successful commissioning, the module should be marked with the date of commission.

If it is anticipated that the un-switched supply may be interrupted before normal use, we advise that the battery is left disconnected and commissioning is delayed until the supply is stable. If mains is not applied after connecting the battery, the unit will continue to draw a minimal amount of power from the battery whilst in standby mode. **Continued use in this state in excess of several months can cause permanent damage to some batteries.**

If the remote emergency pack has been stored for a number of months, it may be necessary to repeat the initial charge/discharge process several times to re-condition the battery and achieve full rated emergency duration.

LED Status:

The status of the remote emergency pack can be determined at any time from the indicator LED. Details of the indicator LED status conditions in both normal and fault conditions are shown in tables 2 and 3 respectively on page 2.

Automatic Testing:

Once commissioned, the remote emergency pack will establish randomised delay times to ensure the next scheduled tests do not coincide with the same test of adjacent remote emergency packs. (See table 1 on page 2 for details of 'Test Delay Time' ranges). Subsequent routine testing will then take place according to the 'Test Interval' times shown in table 1 on page 2. When a scheduled test is due, the remote emergency pack will check to see if the lamp is already in use and avoid disruption to the user for up to 36 hours wherever possible.

To fully reset all test times, disconnect the mains and battery. Once battery is reconnected and power is restored, the commissioning cycle and randomisation process will be reinitiated. Short discharge periods each month for the Function Test will not adversely affect the batteries and should be considered as a maintenance exercise for the battery. Excessive full discharge cycles will however adversely affect the design life of the battery, so excessive testing should be avoided wherever possible. A full summary of automatic test timings can be seen in table 1 on page 2

Testing and Module Status Information

Table 1 - Automatic Testing Information

Test Type	Duration	Test Delay Time	Test Interval/Occurrence	Notes
Commissioning Test	3 Hours	24 Hours	Once*	The module will carry out a Duration Test 24 hours after initial power up. *This test cycle will be repeated if unsuccessful.
Function Test	20 Seconds	1-15 Days	Every 28 Days	
Duration Test	3 Hours*	1-51 Weeks	Every 51 weeks	The module checks if the lamp is in use before initiating a test to avoid disruption. Maximum test delay is 24 hours

Table 2 - Module Status Information

LED Colour	LED Status	On Time (Seconds)		Off Time (Seconds)		Purpose	Action Required
Green	Very Slow Flash	10		0.5		Normal status with fully charged battery. (Commissioned unit)	None – In Standby mode and operating as normal
	Slow Flash	1.5		0.5		First 24 hour charge and Duration Test. (Non-Commissioned unit)	None – Await commissioning process to complete
	Fast Flash	0.5		0.5		Function Test or Duration Test in progress. (Commissioned unit)	None – Await current test to complete
Varied		On	Off	On	Off	Purpose	Action Required
Green	Long on then Flash	10	0.5	0.5	0.5	Battery being charged (Commissioned unit)	None – Await battery to charge (Normally 24 Hours)

Table 3 - Module Status Information Fault Mode

LED Colour	LED Status	On Time (Seconds)	Off Time (Seconds)	Purpose	Action Required
Red	Slow Flash	0.5	1.5	Battery fault	Check battery & connections, repair/replace as necessary
	Fast Flash	0.5	0.5	Lamp or internal circuit fault	Check Lamp & connections repair/replace as necessary

Table 4 - Test Switch Information

Function	Test Switch Action
Start a function test*	Press and release 2 times within 5 seconds

External Wiring Connections

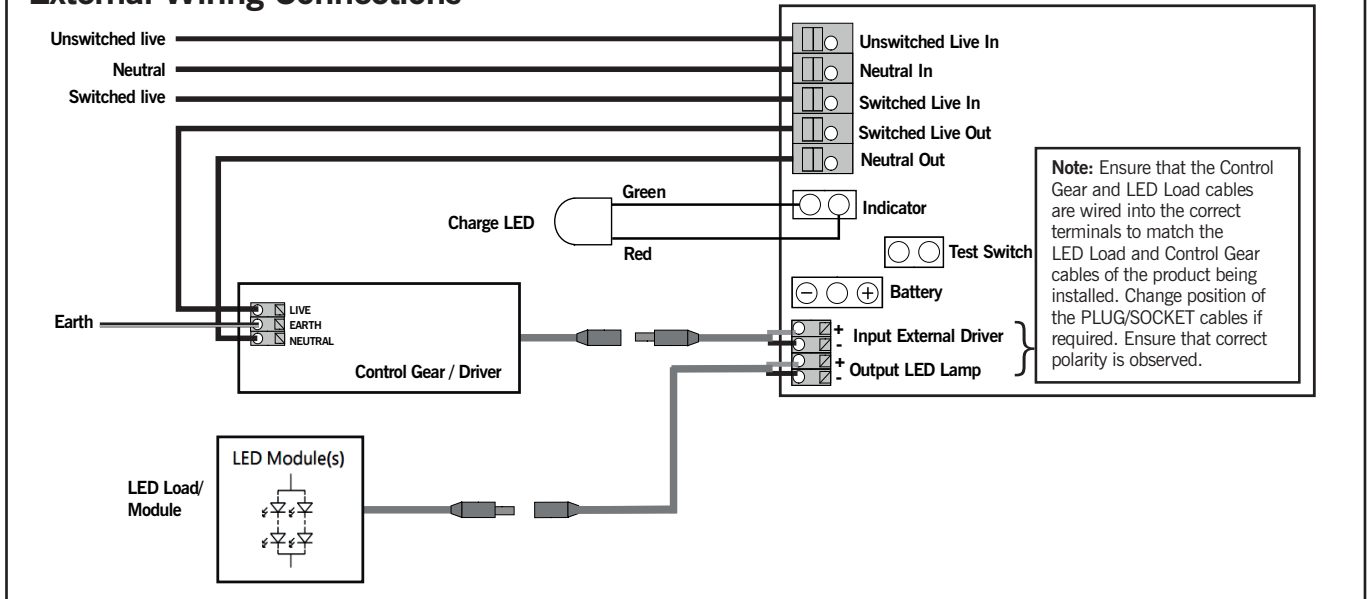

Batteries

Contains replaceable battery: LiFePO4 6.4V 1.5Ah (*5 year warranty excludes batteries)

The battery cells inside an emergency product are a consumable replaceable item. The batteries have a normal operating designed service life of 4 years and must be replaced in a timely manner to ensure that the integrity of the emergency lighting system is maintained. Should the battery cells fail to provide the minimum rated discharge duration of 3 hours at any time during the products service life, they must be replaced.

This product must not be installed in areas where the ambient area temperature is above or below the recommended operating temperature range +5°C to +35°C

Warranty: This product is protected by guarantee in the UK and EU for a period of 5 years* warranty from the date of purchase against any defects in materials or workmanship. Should this product fail during the warranty period it will be repaired or replaced with the same or equivalent product free of charge, subject to providing the original receipt/invoice or proof of the original date of purchase and return of the faulty unit. If in our sole discretion, we are unable to repair or replace a defective product, we will refund the purchase price of the product. The warranty is invalid if in our judgment the product fails due to incorrect installation not conforming to our product instructions or installation within an improper working environment. The warranty will not apply if the product fails due to damage in storage, shipment, accident or misuse. Modification to the product in any way or removal of the batch number will void the warranty. Luxna Lighting does not accept responsibility for any installation, labour or travel costs which may be associated with the replacement or return of any faulty products. Our maximum liability under the terms of this warranty is limited to the purchase price of the product. Your statutory rights are not affected. Luxna Lighting reserves the right to alter product specifications without prior notification. Terms and conditions are also subject to change without prior notice.