

# niglon

## Wiring Accessories

# ARCTIC EDGE

## FS13DPN

13A switched  
fused connection  
unit with neon

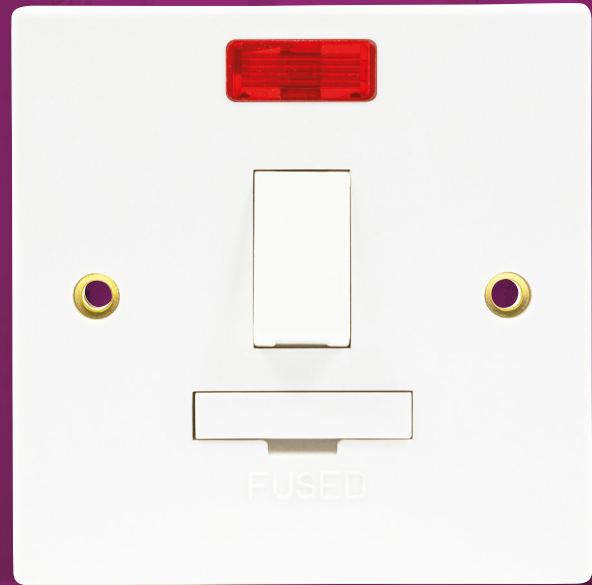

A white, square-edged, moulded accessory manufactured in a robust urea construction. Arctic Edge offers traditional design values for new, or existing installations.

### Technical Drawing

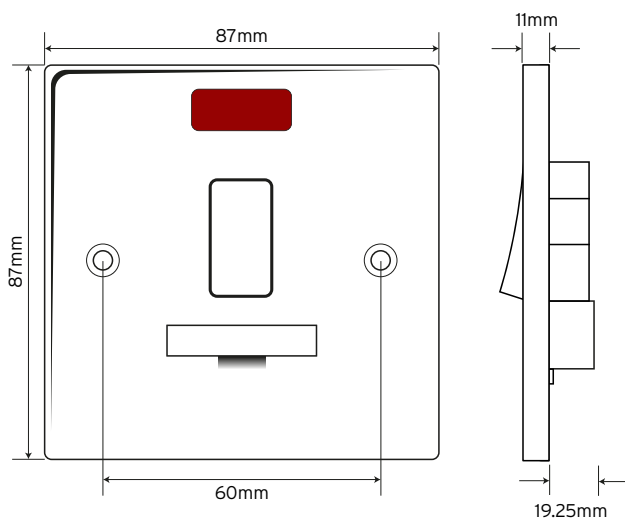

### Technical Specifications

#### Material Composition:

Front Plate	Urea
Rear Housing	Urea
Terminals	Brass
Earth Strap	Mild Steel
Terminal Screws	Steel & Yellow Passivated Silver "on-lay" Copper/Brass Contacts
Voltage	240V ~ 50Hz
Current Rating	13A
Terminal Size	5mm Ø
Torque Value	2.0Nm
Cable Size	3x2.5mm <sup>2</sup> or 2x4.0mm <sup>2</sup>
Back Box Depth	25mm - 47mm
Twin Earth	Yes
Double Pole	Yes
Warranty	20 years
IP Rating	IP20
Operational Temperature	-5° to +40°C
Standards	BS 1363-4:1995+A4:2012 Fuses to BS 1362:1973