

# niGLON

## Circuit Protection

# AEC2/2 Damp Condition Clamps



### Technical Drawing

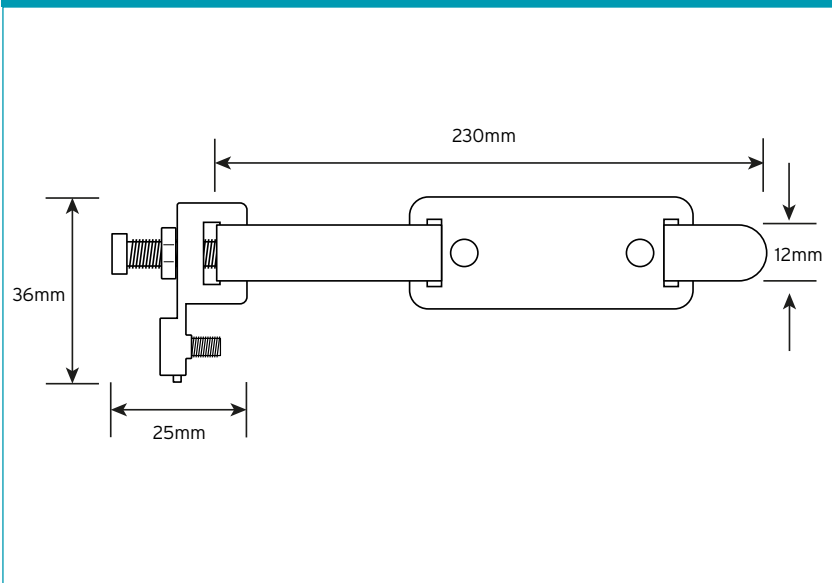

### Technical Specifications

<b>Pipe Diameter</b>	32-50mm
<b>Maximum Conductor</b>	A-D 1 x 10mm <sup>2</sup>
<b>Standard of Compliance</b>	BS 951
<b>Clamp Dimension</b>	25 x 36 x 13mm (H x W x D)
<b>Strap Dimension</b>	12 x 230mm (W x L)